

**PERFECT TOOLS INDUSTRY CO., LTD.**

ADD: NO.9, XINREN 4TH ST., DALI DIST., TAICHUNG CITY, TAIWAN

TEL: +886-4-22764321 / FAX: +886-4-22776665

E-MAIL: [perfect-tool@perfect-tool.com](mailto:perfect-tool@perfect-tool.com)

WEBSITE: <http://www.perfect-tool.com>



**PERFECT TOOLS**®

**AUTO  
REPAIR TOOLS**



**SINCE 2005**

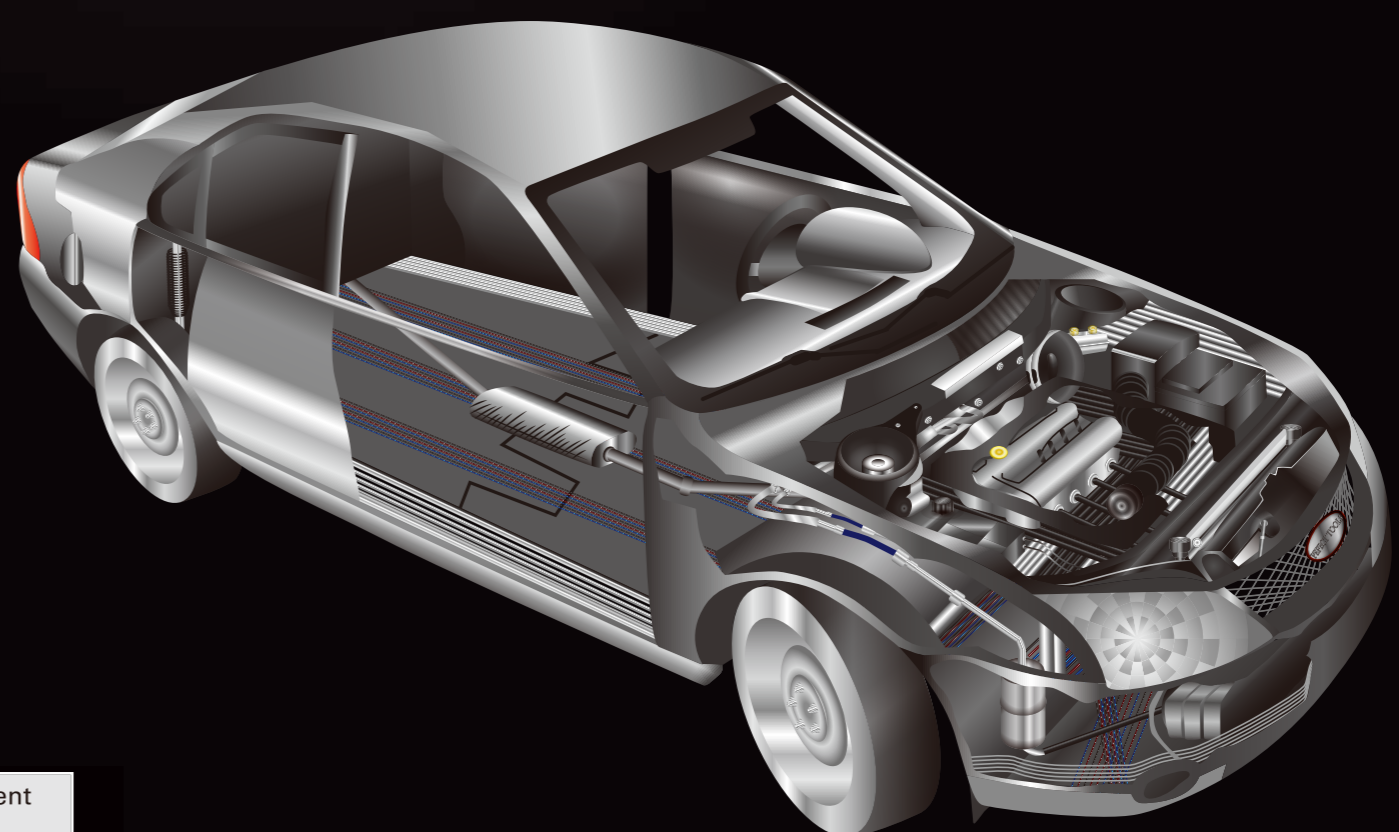

**PERFECT TOOLS**®



Management System  
ISO 9001:2015  
[www.tuv.com](http://www.tuv.com)  
ID 9105053496

**P**TOOLS  
**PERFECT**  
完美工具

# PERFECT TOOLS®

## PERFECT TOOLS INDUSTRY CO.,LTD.

We, Perfect Tools is a well-organized and professional exporter in handling hand tools and auto tools since 2005. Over 10 years' full experience in this field, we have become one of the leading exporters in Taiwan and have been enjoying an excellent reputation in the global market. To ensure our products to be perfect, we invest some capital in doing R&D every year and concentrate on quality control from start to finish.

Basing on customer's interest always comes first and meet their individual needs, we have cooperated with many makers and friends' companies for supplying various items. Focused on sourcing high quality and competitive price products is our goal. We deeply believe that Perfect Tools could be your preferred supplier for Taiwan made products – where you are assured of RELIABILITY, SERVICE and QUALITY. Just giving us a chance, we will prove to be a perfect partner you really need in this business.

A wide range of products and models are for your choice, OEM and ODM cooperation is highly welcome.

Not just the brand,  
it also means.....

Reliability

Service

Quality



# I N D E X

## AUTO TOOL

Timing series (正時工具)	2 ~ 13
Engine series (引擎工具)	14 ~ 24
Undercar series (車底工具)	24 ~ 39
Auto Body series (鈹金工具)	40 ~ 44
Diagnostic series (診斷工具)	44 ~ 45
Air Conditioning series (空調系統工具)	46 ~ 49
General series (一般通用工具)	50 ~ 53

## HAND TOOL

Socket Wrench Set series (套筒扳手工具組)	54 ~ 69
Socket series (套筒)	70 ~ 71
Ratchet Handle series (葫蘆柄)	72 ~ 73
Accessories series (配件)	74 ~ 79
Bit Socket series (起子頭套筒)	80 ~ 81
Ratcheting Wrench series (棘輪扳手/扳手)	82 ~ 85
Impact Socket Set series (氣動套筒組)	86 ~ 91
Impact Socket (氣動套筒)	92 ~ 93
Impact Accessories series (氣動配件)	94 ~ 95
Torque Wrench series (扭力扳手)	96



## TM10001A

### ENGINE TIMING TOOL SET - BMW (N51/N52/N53/N54)

- > Special design to locate camshaft in TDC position.
- > Model: BMW  
E82: 128i (07-08)  
E81/87: 130i (05-08)  
E82: 135is (07-08)  
E90/91/92/93: 323i (04-08), 325i/xi (04-08), 328i/xi (04-08), 330i/xi (04-08), 335i/xi (04-08)  
E70: X5 3.0 (06-08)  
E60/61: 523i/li (04-08), 525i/li/xi (06-08), 528i/li/xi (06-08), 530i/li/xi (05-08), 630i (04-08)  
E83: X3 2.5/3.0 (06-08)  
E63/64: 535i/xi (04-08)  
E65/66: 730i/li (04-08)  
E85/86: Z4 2.5/3.0 (05-08)

### 寶馬正時工具組(N51/N52/N53/N54)

- > 用以定位凸輪軸在上止點的位置
- > 適用: 寶馬 N51/N52/N53/N54  
E82: 128i (07-08)  
E81/87: 130i (05-08)  
E82: 135is (07-08)  
E90/91/92/93: 323i (04-08), 325i/xi (04-08), 328i/xi (04-08), 330i/xi (04-08), 335i/xi (04-08)  
E70: X5 3.0 (06-08)  
E60/61: 523i/li (04-08), 525i/li/xi (06-08), 528i/li/xi (06-08), 530i/li/xi (05-08), 630i (04-08)  
E83: X3 2.5/3.0 (06-08)  
E63/64: 535i/xi (04-08)  
E65/66: 730i/li (04-08)  
E85/86: Z4 2.5/3.0 (05-08)

## TM10002A

### ENGINE TIMING TOOL SET FOR PROFESSIONAL ENGINE REPAIR BMW (N42/N46/N46T)

- > BMW:  
E87 118i / 120i N46 engine  
E46 316i / 316ti / 318ti N42 engine  
E90/E91 318i / 320i / N46 engine  
E85 Z4, 2.0L N46 engine
- > For adjustment and arresting of the twin camshaft on petrol engines:  
-- Engine timing: checking and adjustment  
-- VANOS unit: removal, installation and alignment
- > Easily accessible operating instructions including cross references to original part numbers.
- > Spare parts optionally available.
- > Clear arrangement of tools in high-quality plastic case with soft foam insert.

### 寶馬正時工具組(N42/N46/N46T)

- > 適用: 寶馬 N42/N46/N46T · E87 118i / 120i N46 · E46 316i / 316ti / 318ti N42 · E90/E91 318i / 320i / N46 · E85 Z4, 2.0L N46 引擎
- > 用以調整汽油引擎的雙凸輪軸 · 校正與調節引擎正時工具
- > 多樣配件可供選擇使用

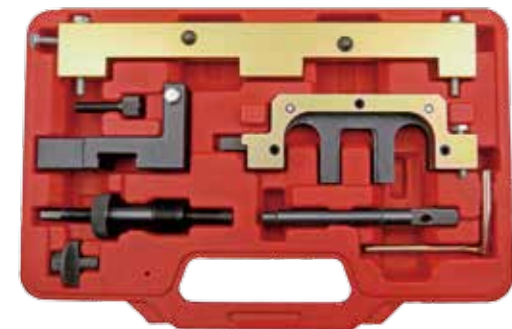

## TM10004A

### DIESEL ENGINE SETTING / LOCKING TOOL SET - BMW N47 (N47S 2.0D)

- > Application: BMW N47 / N47S 2.0D  
E81/E87: 118d  
E81/E82/E87: 120d,123d  
E90/E91: 318d  
E90/E91/E92: 320d  
E60/E61: 520d  
E83: X3 2.0d

### 寶馬正時工具組(柴油)N47 (N47S 2.0D)

- > 適用: 寶馬 N47 / N47S 2.0D雙凸輪軸柴油鏈條引擎  
E81/E87: 118d  
E81/E82/E87: 120d,123d  
E90/E91: 318d  
E90/E91/E92: 320d  
E60/E61: 520d  
E83: X3 2.0d

## TM10007A

### PETROL ENGINE TWIN CAMSHAFT SETTING / LOCKING TOOL KIT- BMW(N40/N45/N45T)

- > Checking and adjustment of timing.
- > Models : B16 (N40 / N45 / N45T)
- > Engines:  
1 series : 116i (E81/E87)  
3 series : 316i (E46/E90), 316ci (E46), 316ti (E46)

### 寶馬正時工具組(N40/N45/N45T)

- > 適用: 寶馬 B16 (N40/N45/N45T)
- > 用以校正正時工具



## TM10008A

### ENGINE TIMING TOOL SET - BMW(M42/M44/M50/M52/M54/M56)

- > Application: BMW M42/M44/M50/M52/M54/M56
- > Installation/removal and timing of variable camshaft timing unit.
- > Checking and adjustment of camshaft timing/belt changing.

### 寶馬綜合正時工具組(M42/M44/M50/M52/M54/M56)

- > 適用: 寶馬 M42/M44/M50/M52/M54/M56
- > 用以拆裝可變式凸輪軸的正時裝置 · 凸輪軸的檢驗和校正/更換皮帶



MODEL (型號)	ENGINE (引擎)	MODEL (型號)	ENGINE (引擎)	MODEL (型號)	ENGINE (引擎)
E46	316 Bj. 99-04	E38	328i Bj. 95-99 SV	E38	728i Bj. 95-98 SV
E36	316i Bj. 93-93	E46	328i Bj. 98-01 TV		728i Bj. 98-02 TV
	316i Compact Bj. 94-01 (M43)		330i Bj. 00-06 TV		
E36	318i Bj. 93-99 (M43)	E34	518i Bj. 94-96 (M43)	E65/E66	730i Bj. 02-05 TV
E46	318i Bj. 98-04 (M43)		520i Bj. 89-96		
E30	318iS-16V. Bj. 89-91 (M42)	E43	520i Bj. 89-96 SV	E83	X3-2.5i Bj. 03-06 TV
E36	318iS/Coupe Bj. 92-98	E39	520i Bj. 95-99 SV (M54)		X3-3.0i Bj. 03-06 TV
	318ti Compact Bj. 94-98/(M42)		520i Bj. 98-03 TV	E53	X5-3.0i Bj. 99-05 TV(M54)
	318iS/Coupe Bj. 96-99	E60/E61	520i Bj. 03-05 TV		Z3-1, 8i Bj. 96-99
	318ti compact Bj. 96-01/(M44)	E39	523i Bj. 95-99 SV		1.9i Bj. 99-03 (M43/M44)
	320i Bj. 91-97		523i Bj. 98-01 TV (M52)		2.0i Bj. 99-03 TV (M52)
	320i Bj. 91-99 SV	E34	525i Bj. 89-96		2.2i Bj. 00-03 TV (M52)
E36/E46	320i Bj. 98-06 TV (M52)		525i Bj. 89-96 SV		2.8i Bj. 97-99 SV
E36/E46	323i Compact Bj. 95-01 SV	E39	525i Bj. 00-03 TV		2.8i Bj. 00-03 TV
		E60/E61	525i Bj. 03-05 TV		3.0i Bj. 00-03 TV (M52)
E46	323i Bj. 98-01 TV (M52)	E39	528i Bj. 96-00 SV	E85	Z4-2.2i Bj. 03-06 TV
E36	325i Bj. 91-97		528i Bj. 96-01 TV (M52)		2.5i Bj. 03-06 TV
	325i Bj. 91-97 SV		530i Bj. 00-03 TV		3.0i Bj. 03-07 TV
E46	325i Compact Bj. 00-06 TV	E60/E61	530i Bj. 03-05 TV		



### TM10009A ENGINE TIMING TOOL SET – BMW (M50)

- > Models:  
E46: 318D 320D 330D  
E39: 520D 525D 530D  
E38: 730D
- > Engine Type: M50

#### 寶馬正時工具組 (M50)

- > 適用: 寶馬 E46: 318D 320D 330D · E39: 520D 525D 530D · E38: 730D
- > 引擎型號:M50



### TM10010A ENGINE TIMING TOOL SET – BMW (M47)

- > This set enables the correct timing to be made when servicing BMW M47 2.0 16 Engines.
- > Models:  
E46: 318D 320D 330D  
E39: 520D 525D 530D  
E38: 730D

#### 寶馬正時工具組(M47)

- > 適用: 寶馬 M47 2.0 16引擎
- > 型號:  
E46: 318D 320D 330D  
E39: 520D 525D 530D  
E38: 730D



### TM10011A CAMSHAFT ALIGNMENT TOOL-BMW (N51/N52/N53/N54/N55)

- > Applications: BMW N51/N52/N53/N54/N55 engines.
- > Special design to locate camshaft in TDC position.

#### 寶馬正時工具組(N51/N52/N53/N54/N55)

- > 適用: 寶馬 N51/N52/N53/N54/N55
- > 用以定位凸輪軸在上止點的位置



### TM18001A ENGINE TIMING TOOLS SET FOR MERCEDES BENZ / CHRYSLER / JEEP

- > A timing tool set which covers a large of models in the Mercedes range including Petrol and Diesel engines.
- > Also suitable for Chrysler PT Cruiser 2.2 CRD and Jeep Grand Cherokee 2.7 CRD.
- > Set includes flywheel plate locking tools and camshaft locking pin set.

#### 賓士/克萊斯勒/吉普正時工具組

- > 適用於多種賓士汽/柴油引擎車款
- > 也適用在克萊斯勒(PT Cruiser 2.2 CRD)和吉普(Grand Cherokee 2.7 CRD)
- > 內含飛輪盤固定工具和凸輪軸固定插銷組



### TM18002A BENZ ALIGNMENT TOOL SET (M271)

- > Applicable: BENZ M271
- > This retaining device makes it possible to position the camshafts in the installed position.
- > Retainer to draw in the timing chain. To retain timing chain with camshaft sprockets in mesh.

#### 賓士正時工具組(M271)

- > 適用: 賓士 M271
- > 此固動裝置得以在安裝位置定位凸輪軸 · 保持正時鍊條能與凸輪軸鍊輪啮合



### TM18004A TIMING TOOL SET - MERCEDES BENZ (M157 / M276 / M278)

- > Applications: BENZ M157, M276, M278 engine
- > Used to align the camshaft timing angle for correct position.

#### 賓士正時工具組

- > 適用: 賓士 M157, M276, M278 引擎
- > 用以調整凸輪軸正時角度為正確位置



## TM20001

### HONDA / ACURA CRANKSHAFT DAMPER HOLDING TOOL

- > Tool allows the technician to hold the crankshaft damper when tightening or loosening the crankshaft bolt.
- > Works on the following Honda and Acura engines:
  - 1990-1997 Honda Accord 2.2L 4 cyl.
  - 1996-1997 Honda Accord 2.7L V-6
  - 1998-newer Honda Accord 2.3L 4 cyl. & 3.0L V-6
  - 1992-newer Honda Civic 1.6L 4 cyl.
  - 1997-newer Honda CR-V 2.0L 4 cyl.
  - 1993-1997 Honda Del Sol 1.6L 4 cyl.
  - 2000-newer Honda Insight 1.0L 3 cyl.
  - 1995-1997 Honda Odyssey 2.2L 4 cyl.
  - 1998 Honda Odyssey 2.3L 4 cyl.
  - 1999-newer Honda Odyssey 3.5L V-6
  - 1992-newer Honda Prelude 2.2L 4 cyl.
  - 1997 Acura CL 2.2L 4 cyl.
  - 1997-1998 Acura CL 3.0L V-6
  - 1992-1996 Honda Prelude 2.3L 4 cyl.
  - 2000- newer Honda S2000 2.0L 4 cyl.
  - 1998-1999 Acura CL 2.3L 4 cyl.
  - 2000-newer Acura CL 3.2L V-6
  - 1990-1992 Acura Integra 1.6L 4 cyl.
  - 1992-1993 Acura Integra 1.7L 4 cyl.
  - 1993-newer Acura Integra 1.8L 4 cyl.
  - 1991-1995 Acura Legend 3.2L V-6
  - 1996-newer Acura RL 3.5L V-6
  - 1995-newer Acura TL 3.2L V-6

### 本田正時皮帶盤支檔扳手

- > 適用本田和雅格系列引擎
- > 當在鎖緊或鬆開曲軸螺栓時，此工具可使技師握住曲軸減震器

## TM30001A1

### 2PCS CAMSHAFT CENTRAL VALVE TOOL

- > For Audi A3 (2003 -) .A4.A5.Q5, VW Passat (2006 -) . Passat CC (2006 -) with engine above.
- > Applicable with 4-cylinder gas direct injection, 1.8 liter, 2.0 liter, 4V, TFSI engine with chain.
- > Assembly tool for installation and removal 4/3-way central valve for camshaft adjustment.
- > These tools have offset pins.

### 2件福斯/奧迪凸輪軸調整套筒

- > 適用: 奧迪A3 (2003 -) . A4.A5.Q5 · 福斯 帕薩特 (2006 -) . 帕薩特 CC (2006 -) 引擎
- > 適用4缸汽油噴射1.8升, 2.0升, 4V, TFSI鏈條引擎
- > 此裝配工具用於凸輪軸的調整以安裝和拆卸4/3向中心閥門
- > 各內嵌2個插銷以轉動凸輪軸至定位點



## TM30001B

### 3PCS CAMSHAFT CENTRAL VALVE TOOL

- > For Audi A3 2003>, A4, Q5 , VW Passat/Passat CC 2006>, Golf 2003>, SEAT, Skoda with engine above.
- > Audi TT 2006>, Audi A4 2008 >, Audi A52008 >, Audi Q5 2008 >, Audi A3 2012 >
- > Applicable with 4-cylinder gas direct injection, 1.8 liter, 2.0 liter, 4V, TFSI engine with chain.
- > Assembly tool for installation and removal 4/3-way central valve for camshaft adjustment.
- > Also used for 3rd generation 4-cyl. 1.8l, 2.0l 4V TFSI direct injection engine which across all brands and platforms for VW group.

### 3件福斯/奧迪凸輪軸調整套筒

- > 適用: 奧迪A3 2003>, A4, Q5, 福斯 帕薩特 / 帕薩特 CC 2006>, 高爾夫 2003>, 喜悅, 司科達引擎
- > 適用: 奧迪TT 2006>, 奧迪 A4 2008 >, 奧迪A5 2008 >, 奧迪Q5 2008 >, 奧迪A3 2012 >
- > 適用4缸氣體直噴1.8升, 2.0升, 4V, TFSI鏈條引擎 · 也適用福斯集團第三代4缸氣體直噴 1.8升 · 2.0升 · 4V · TFSI引擎
- > 此裝配工具用於凸輪軸的調整以安裝和拆卸4/3向中心閥門
- > 各內嵌2個插銷以轉動凸輪軸至定位點

## TM30002C

### ENGINE TIMING TOOL SET - AUDI 3.2 FSI

MODEL(福斯/奧迪型號)	ENGINE(引擎)	YEAR(年份)
A6 2.4	BDW	04-07
A6 2.4 quattro	BDW	04-07
A4 3.2 FSI	AUK	04-07
A6 3.2 FSI	AUK, BKH	04-07
A8 3.2 FSI		05-07

### 福斯/奧迪正時工具組(3.2 FSI)

- > 適用: 奧迪 (3.2 FSI)



## TM30004

### CRANKSHAFT LOCKING TOOL VAG2.0- BELT DRIVE

- > Special design to lock the crankshaft on VW-AUDI, SEAT, SKODA, 2.0 TDI engine.

### 福斯/奧迪曲軸正時固定器

- > 用以固定於福斯-奧迪、喜悅、司科達 2.0 TDI 引擎的曲軸





### TM30005 CAMSHAFT SETTING BRACKET

- > This revised Camshaft Setting Bracket for VW's now gives even better alignment with 2 ground shoulder screws included in the set.
- > This time-saving product means essential timing adjustment can take place with the vacuum pump and cam cover still in place.
- > The Camshaft Setting Bracket can be offered to the camshaft slot by sliding it along the dowel screws.
- > An additional knob is incorporated in the tool to assist with precision alignment.

#### 福斯/奧迪正時工具組-雙凸輪固定

- > 這修正的凸輪軸支架對福斯汽車來說提供了更好的調準，並含有2接地凸肩螺絲

### TM30006A ENGINE TIMING TOOLS W/ 4 GROOVES -VAG

- > Models: VW, Audi, Skoda, Seat
- > Engine types: AFK, AHW, AKQ, APE, AQQ, AUA, AUB, AXO, BBY, BBZ, BCA, BKY, BUD, BXW, AAR, AJV, ARC, ATN, AUS, AVY, AZD, BCB, BAD, AWY, AZQ, AMF, ANY, ASZ, ATD, AXR, BHC, BKC, AJM, AWX, ANU, ARL, AYZ, AFB, AKN, AKE, AYM, BAU, BCZ, BDG, BDH, BFC, AZV, BKD, BDJ, BDK, BGW, BHW, BKP, BLB, BMA, BMM, BMN, BMP, BMR, BNA, BPW, BRC, BRE, BRF, BSS, BUY BUZ, BVE, BVF, BVH, BWV, CAYA, CAYB, CAYC, CAGA, CAGB, CAGC, CAHA, CAHB, CBAA, CBAB, CBAC, CBBA, CBDA, CBDB, CBDC, CBEA, CEGA
- > Engines:  
Petrol: 1.2 6V, 1.2 12V, 1.4 16V, 1.6 16V (belt), 1.4FSI, 1.6 FSI  
Diesel: 1.2/1.4/1.9 TDI, 2.5 V6 TDI, 3.3 V8 TDI, 2.0 TDI (PD) / 2.0 TDI (Common Rail), 1.6 TDI (Common Rail)

#### 福斯/奧迪正時工具組

- > 適用: 福斯、奧迪、司科達、喜悅
- > 引擎型號: AFK, AHW, AKQ, APE, AQQ, AUA, AUB, AXO, BBY, BBZ, BCA, BKY, BUD, BXW, AAR, AJV, ARC, ATN, AUS, AVY, AZD, BCB, BAD, AWY, AZQ, AMF, ANY, ASZ, ATD, AXR, BHC, BKC, AJM, AWX, ANU, ARL, AYZ, AFB, AKN, AKE, AYM, BAU, BCZ, BDG, BDH, BFC, AZV, BKD, BDJ, BDK, BGW, BHW, BKP, BLB, BMA, BMM, BMN, BMP, BMR, BNA, BPW, BRC, BRE, BRF, BSS, BUY BUZ, BVE, BVF, BVH, BWV, CAYA, CAYB, CAYC, CAGA, CAGB, CAGC, CAHA, CAHB, CBAA, CBAB, CBAC, CBBA, CBDA, CBDB, CBDC, CBEA, CEGA
- > 引擎:  
汽油引擎: 1.2 6V, 1.2 12V, 1.4 16V, 1.6 16V (belt), 1.4FSI, 1.6 FSI  
柴油引擎: 1.2/1.4/1.9 TDI, 2.5 V6 TDI, 3.3 V8 TDI, 2.0 TDI (PD) / 2.0 TDI (Common Rail), 1.6 TDI (Common Rail)



### TM30007 CAMSHAFT ALINGNMENT TOOL SET - VW AUDI (1.4/1.6)

- > Applications: VW, AUDI 1.4/1.6
- > Models:  
VW: Lupo, Polo, Golf IV, Bora  
Audi: A2 (00-06)
- > Engines: 1.4 16V, 1.4 FSI, 1.6 16V, 1.6 FSI

#### 福斯/奧迪正時工具組 (1.4/1.6)

- > 適用: 福斯、奧迪 1.4/1.6
- > 車型:  
福斯: 路寶、波羅、高爾夫IV、寶來  
奧迪: A2 (00-06)
- > 引擎型號: 1.4 16V, 1.4 FSI, 1.6 16V, 1.6 FSI

### TM30008A PETROL ENGINE TWIN CAMSHAFT SETTING / LOCKING TOOL KIT - VW / AUDI

- > To check and adjust camshaft timing. Required when replacing timing belts or timing chains or engine repairs.
- > Models:  
VW: Polo, Golf, Golf Plus, Touran  
Audi: A3  
Skoda: Ocatvia
- > Engines types: AXU, BAG, BKG, BLF, BLN, BLP

#### 福斯/奧迪正時工具組

- > 用以檢驗與校正凸輪軸正時工具，以替換正時皮帶、正時鏈或引擎修護時
- > 車型:  
福斯: 波羅、高爾夫、高爾夫進階版、途安  
奧迪: A3  
司科達: Ocatvia
- > 引擎型號: AXU, BAG, BKG, BLF, BLN, BLP



### TM30009A VW/AUDI ENGINE TIMING TOOL SET (2.0 FSI)

- > Applicable: AUDI A3 2.0 FSI and FSI SOHC engine codes: AWA, BHD, BMB VW GOLF 2.0 FSI and 2.0 FSI SOHC and Touran 2.0 FSI SOHC engine codes: AWA, AXW.
- > With camshaft tools, chain tensioner retainer, locking pins and tensioner bolt.
- > For 2.0 FSI petrol engines since 2003.

#### 福斯/奧迪正時工具組(2.0 FSI)

- > 適用: 奧迪 A3 2.0 FSI and FSI SOHC · 引擎型號:AWA, BHD, BMB 福斯 高爾夫2.0 FSI 和 2.0 FSI SOHC · 途安 2.0 FSI SOHC 引擎型號: AWA, AXW
- > 搭配凸輪軸工具, 鍊條張緊固定器, 固定銷和張緊螺栓
- > 用於自2003年2.0 FSI汽油引擎





## TM30010A

### CRANKSHAFT LOCKING PIN – VW / AUDI

- For locking the crankshaft at the TDC position when replacing timing belt or removing crankshaft bolt.
- #1: CRANKSHAFT LOCKING PIN – VW / AUDI (2.0, 2.4, 2.8, 3.0, 3.2 FSI)  
Application: VW / Audi engines: 2.5L I-5 cyl.  
(BGP, BGQ, BPR, BPS, CBTA and CBUA) 3.2L V6 4v (BKH and CALA)  
Size: M14 x P1.5
- #2: CRANKSHAFT LOCKING PIN – VW / AUDI (1.4, 1.6 FSI, TSI)  
Size: M14 x P1.5
- #3: V6 CRANKSHAFT LOCKING PIN – VW/ AUDI  
Size: M18 X P1.5
- #4: V6 CRANKSHAFT LOCKING PIN – VW/ AUDI  
Size: M12 X P1.5



1. 2. 3. 4.

### 福斯/奧迪曲軸固定插銷

- 於替換正時皮帶或拆卸(發動機)曲軸螺栓時·用以定位(發動機)曲軸於止點位置
- #1 凸輪軸固定插銷-福斯/奧迪(2.0, 2.4, 2.8, 3.0, 3.2 FSI)  
適用: 福斯/奧迪 引擎:2.5L I-5缸  
(BGP, BGQ, BPR, BPS, CBTA和CBUA) 3.2L V6 4v (BKH和CALA)  
規格:M14 x P1.5
- #2 凸輪軸固定插銷-福斯/奧迪 (1.4, 1.6 FSI, TSI)  
規格:M14 x P1.5
- #3 V6凸輪軸固定插銷-福斯/奧迪  
規格:M18 x P1.5
- #4 V6凸輪軸固定插銷-福斯/奧迪  
規格:M12 x P1.5

## TM30013

### AUDI CAMSHAFT ADJUSTING SOCKET

- Applicable : AUDI AVK (2000~2004) BBK AUDI 3.0L V6
- Special groove nut socket to turn the camshaft adjuster into position.
- Camshaft Adjusting Socket used to adjust variable valve timing on the exhaust side camshaft to basic position.



### 福斯/奧迪凸輪軸調整套筒

- 適用: 奧迪AVK(2000~2004) BBK 奧迪 3.0L V6
- 特殊凹口套筒旋轉凸輪軸調節至適當位置

## TM42001A

### ENGINE TIMING TOOL SET-FORD

- Applicable: Ford Focus/ Cmax 1.6 Ti-vct 2003 later, 2.0 Tdci
- Engine code: HXDA, G6DA, G6DB, G6DC 2003 later
- Installation and removal of camshaft / variable camshaft timing unit.
- Checking and adjustment of timing.



### 福特正時工具組

- 適用: 福特 Focus/ Cmax 1.6 Ti-vct 2003 later, 2.0 Tdci
- 引擎型號: HXDA, G6DA, G6DB, G6DC 2003 later
- 用以安裝拆卸凸輪軸·檢驗與校正正時工具



## TM50001A

### ENGINE TIMING TOOL SET – CITROEN & PEUGEOT

- Applicable: CITROEN and PEUGEOT Twin Cam 16V Petrol engine codes (EW7J4, EW10J4, EW10J4S, EW10D-HPi, EW12J4).  
CITROEN: Xsara / Picasso C4, C5, Evasion / Synergie, C8, Jumpy / Dispatch  
PEUGEOT: 206, 307, 406/Coupe, 607, 806, 807, Expert.
- This comprehensive set of tools enables the correct engine timing to be made when replacing the timing belt.
- Suitable for using on the most recent car with either HPI(petrol)or HDI (diesel) engines.

### 雪鐵龍/寶獅正時工具組

- 適用: 雪鐵龍和寶獅雙凸輪16V汽油引擎型號(EW7J4, EW10J4, EW10J4S, EW10D-HPi, EW12J4)  
雪鐵龍: Xsara / Picasso C4, C5, Evasion / Synergie, C8, Jumpy / Dispatch  
寶獅: 206, 307, 406/Coupe, 607, 806, 807, Expert
- 用以替換正時皮帶時·可修正引擎正時工具組
- 適用於大部分近來的汽車·直噴汽油機或高壓直噴共軌柴油發動機

## TM50002A

### ENGINE TIMING TOOL SET-CITROEN & PEUGEOT

- Suitable for use on the most recent cars with either HPI (petrol) or HDI (diesel) engines.
- Application:  
Locking the flywheel / camshaft / crankshaft  
Removal and assembly of fuel injection pump and water pump  
Changing the timing belt
- Also suitable for identical engines in :  
Fiat, Ford, Nissan, Renault, Rover, Toyota, etc.
- Models:  
Citroen: AX, ZX, XM, Visa, Xsara, Xantia, Dispatch, Synergie/Evasion, Berlingo, Jumpy, C2, C3, C5, Relay/Jumper  
Peugeot: 106, 205, 206, 305, 306, 307, 309, 405, 406, 406 Coupe, 605, 607, 806, 807, Express, Expert, Partner, Boxer
- Engines:  
1.4, 1.5, 1.7, 1.8, 1.9, 2.1, 2.5D/TD/TDI  
1.4, 1.6, 2.0, 2.2 HDI

### 雪鐵龍/寶獅正時工具組

- 適用於大部分近來的汽車·直噴汽油機或高壓直噴共軌柴油發動機
- 用於鎖定飛輪/凸輪軸/(發動機)曲軸
- 拆卸組裝燃油噴油器幫浦與水幫浦
- 替換正時皮帶  
也適用相同的引擎·汽車廠牌如:飛雅特·福特·日產·雷諾·路華·豐田等...
- 車型:  
雪鐵龍: AX, ZX, XM, Visa, Xsara, Xantia, Dispatch, Synergie/Evasion, Berlingo, Jumpy, C2, C3, C5, Relay/Jumper  
寶獅: 106, 205, 206, 305, 306, 307, 309, 405, 406, 406 Coupe, 605, 607, 806, 807, Express, Expert, Partner, Boxer
- 引擎  
1.4, 1.5, 1.7, 1.8, 1.9, 2.1, 2.5D/TD/TDI  
1.4, 1.6, 2.0, 2.2 HDI





### TM52001A CAMSHAFT/CRANKSHAFT ALIGNMENT TOOL-VOLVO

- > Models: 850, 960, S40, S70, S90
- > For alignment of the cam and crankshafts.
- > Also enables correct installation of the camshafts with the cam cover.

#### 富豪正時工具組

- > 適用: 富豪 850, 960, S40, S70, S90
- > 用以調準凸輪與曲軸
- > 同時也可正確的安裝在凸輪軸的凸輪蓋



### TM90001A ENGINE TIMING TOOL KIT - TOYOTA, MITSUBISHI

- > For Toyota, Mitsubishi
- > Important kit when working on timing belt, general motor settings, camshafts

#### 豐田, 三菱正時工具組

- > 適用豐田、三菱
- > 使用於正時皮帶、一般通用電機設置、凸輪軸之工具組
- > 豐田與三菱發動機曲軸皮帶盤與鏈條齒輪間的定位



### TM90002A PETROL ENGINE TWIN CAMSHAFT SETTING / LOCKING TOOL KITS - BMW MINI, CITROEN, PEUGEOT

- > Models:  
BMW Mini: R55 R56 Cooper S, R55 R56 Cooper, R56 Mini One  
Citroen: C4, C4 Picasso  
Peugeot: 207, 308
- > Engines:  
BMW: N12 (1.4/1.6), N14 (1.6)  
PSA: EP3, EP6, EP6 DT/DTS

#### 寶馬MINI, 雪鐵龍, 寶獅正時工具組

- > 適用汽車廠牌:  
寶馬Mini: R55 R56 Cooper S, R55 R56 Cooper, R56 Mini One  
雪鐵龍: C4, C4 Picasso  
寶獅: 207, 308
- > 引擎:  
寶馬: N12 (1.4/1.6), N14 (1.6)  
寶獅和雪鐵龍: EP3, EP6, EP6 DT/DTS



### TM90003A TWIN CAMSHAFT LOCKING & SETTING KIT

- > Suitable for a range of vehicles including: Ford, Honda, Land Rover, Rover and Vauxhall / Opel
- > FOR PETROL ENGINES
- > The kit supplied with adequate tools to lock the camshafts on twin cam (multi-valve) engines in order to stop them rotating out of timed position when the timing belt is replaced and removed.
- > It also provides different camshaft locking pins that can cover specific crankshaft and flywheel locking applications.
- > Allows the service easier and reduce the risk of incorrect valve timing from taking place.

#### 綜合型正時固定器

- > 適用: 福特、本田、荒原路華、路華、沃克斯豪爾/歐寶
- > 用於汽油引擎
- > 當於更換或拆卸正時皮帶時，用以固定位於雙凸輪(多汽)閥門引擎的凸輪軸，以避免轉出正時位置
- > 此組也提供了不同規格的凸輪軸固定插銷，以固定凸輪軸與飛輪
- > 使用更快速方便，並減少不正確(汽)閥門正時發生的危險



### TM97001 UNIVERSAL TENSIONING GAUGE FOR CAM BELTS

- > It can be used to adjust the tension on the cam belt where the movement of timing belt is measured by load(NM).
- > Suitable for use on various cam belt widths.
- > Easy to use.
- > Clear incremental marking with knurled knob for precise measurement.

#### 通用型皮帶張力器

- > 用以使用調節凸輪皮帶上的張力運作，並同步帶測量負載(牛頓米)
- > 適用於多種凸輪皮帶的寬帶
- > 易於使用
- > 清楚增量標記滾花旋鈕把手，可用以精確測量



### TM97002A BELT TOOL KIT FOR ELASTIC-RIBBED BELTS

- > Suitable for engines with elastic ribbed belts such as Alfa Romeo, BMW, Chrysler, Fiat, Ford, Mercedes, PSA, Seat, Skoda, Smart, Volvo, VW-Audi, etc.
- > This tool set is quickly and easily removal and installation of the new elastic ribbed belts required.

#### 正時皮帶拆裝輔助器

- > 適用引擎彈性帶肋帶如愛快羅密歐、寶馬、克萊斯勒、飛雅特、福特、賓士、寶獅和雪鐵龍、喜悅、司科達、司麥特、富豪、福斯-奧迪等...
- > 此組工具可快速容易地裝卸新的彈性帶肋帶  
註:(帶肋帶:帶上有縱向的V形肋條，與傳動帶盤上的槽相吻合)



### TM97003A BALANCER PULLER & INSTALLER

- > A professional tool set for balancer replacement.
- > Built-in bearing makes balancer replacing job easy and damage-free.
- > 4-slot puller plate plus 9 threaded adapters fit to balancers on most engines.

#### 正時皮帶盤拆裝器

- > 平衡器替換專業工具組
- > 內置培林使平衡器替換工作容易
- > 4插槽拆卸盤加9個螺紋接頭適用大部分引擎平衡器





### EG30001 ENGINE CYLINDER HONE

- > Collar prevents stone breakage.
- > Sleeve makes insertion in cylinder easy and protects stones when not in use.
- > Capacity: 2" ~ 7" (51~178mm)
- > Stone size: 102 x 11 x 6.3mm 3pcs

#### 氣缸三爪內徑研磨器

- > 軸環避免磨石破損。當不使用時，方便收納，套管易於插入氣缸內與保護磨石
- > 三爪張力範圍: 2" ~ 7" (51~178mm) · 磨石規格: 3件 102 x 11 x 6.3mm



高度

### EG30002 PISTON RING COMPRESSOR

- > Special spring steel
- > Heat-treated
- > Ratchet type complete with spanner
- > With safety adjusting screws

#### 活塞環壓縮器

- > 採用高強度特殊彈簧鋼，經熱處理，經久耐用，配有棘輪帶鎖裝置更安全
- > 使用活塞環壓縮器時，按下墊片壓縮器就會擴張，再用L扳手以調節尺寸
- > L扳手，硬度大，堅固耐用
- > 外表面上設有扣緊帶，環形帶繞在轉動圓柱上，可調節，不易損壞
- > 環帶與圓柱連接處有螺釘固定，使之不易脫落，耐用



高度

ITEM NO.(編號)	HEIGHT(規格)	CAPACITY(範圍)	QTY/CTN(數量/箱)	G.W.(KGS)(毛重)	CUFT(材積)
EG30002-1	3"	53-125mm	60 PCS	17.50	2.0'
EG30002-2	3-1/2"	53-125mm	60 PCS	18.30	2.0'
EG30002-3	3"	90-175mm	60 PCS	19.50	2.0'
EG30002-4	3-1/2"	90-175mm	60 PCS	20.50	2.0'
EG30002-5	4"	90-175mm	60 PCS	22.00	2.6'
EG30002-6	6"	90-175mm	40 PCS	25.00	3.0'
EG30002-7	6-1/2"	90-175mm	40 PCS	26.50	3.3'



### EG30003 PISTON RING PLIER

- > For removing and mounting piston rings.
- > Special steel
- > Nickel-plated

#### 德式活塞環撥開鉗

- > 專用以拆卸與安裝活塞環
- > 特殊鋼製、鍍鎳
- > 使用活塞環撥開鉗時，將撥開鉗上的環卡卡住活塞環開口，握住手把，使鉗手把慢慢地收縮，環卡將活塞環慢慢地張，使活塞環從活塞環槽中取出或置入
- > 使用活塞環撥開鉗拆裝活塞環時，須避免用力過猛而導致活塞折斷，以避免傷手事故

ITEM NO.(編號)	CAPACITY(範圍)	QTY/CTN(數量/箱)	G.W.(KGS)(毛重)	CUFT(材積)
EG30003-1	50-100mm	48 PCS	16.50	2.1'
EG30003-2	80-120mm	48 PCS	18.00	2.4'
EG30003-3	110-160mm	48 PCS	23.00	3.4'



### EG30004A VALVE LAPPERS

- > For hand lapping valves.
- > 1-1/8"(29mm) and 1-3/8"(35mm) diameter cups for large valves.
- > 5/8"(16mm) and 13/16"(21mm) diameter cups for small valves.

#### 手動凡爾研磨器

- > 適用大部分車型的氣門研磨工具
- > 用以手動使用兩種直徑規格的小型與大型凡爾研磨器
- > 真空杯的直徑規格有(小)1-1/8"(29mm)、1-3/8"(35mm)  
(大)5/8"(16mm)、13/16"(21mm)



### EG30006A PISTON RING SERVICE TOOL SET

- > Piston ring compressor w/ratchet key  
H: 3" (Capacity 53-125mm), H: 3-1/2" (Capacity 90-175mm),  
H: 4" (Capacity 90-175mm)
- > Piston ring tool capacity: 50-100mm
- > Piston ring groove cleaning  
Fits: 2" - 5" (51 to 127mm)  
Blade 1 size: 1/16" to 3/16"  
Blade 2 size: 2.0mm to 4.5mm, 1/4"  
Blade 3 size: 1.2mm to 5.5mm
- > Offset screwdrivers: ⊕ ⊖

#### 6件活塞環維修組

- > 用以拆卸與安裝活塞環
- > 規格: 3" (範圍 53-125mm), 規格: 3-1/2" (範圍 90-175mm), 規格: 4" (範圍 90-175mm)
- > 活塞環工具適用範圍: 50-100mm
- > 活塞環清理凹槽適用: 2" - 5" (51 - 127mm)  
刮片1號: 1/16" - 3/16"  
刮片2號: 2.0mm - 4.5mm, 1/4"  
刮片3號: 1.2mm - 5.5mm
- > S型雙頭螺絲起子: 十字、一字





### EG37001

#### VALVE SPRING COMPRESSOR

- > Compressor easily removes valve springs on most cars and light trucks, works with cylinder head on or off the engine.
- > Instructions included:  
Remove valve cover  
Place tool around valve spring as low as possible to fit spring coils.  
Screw down handle until spring is compressed sufficiently to remove keys and spring.

#### 汽門彈簧拆卸器 手動扭轉式

- > 易於拆卸大部份車輛與輕型卡車的汽門彈簧



### EG37002

#### VALVE SPRING COMPRESSOR

- > Remove and install valve springs with the heads on or off the engine.
- > Fits 3/8" and 7/16" rocker studs
- > Handles 1" - 2" diameter springs
- > Press down to compress coil spring, then remove valve keepers and release slowly.

#### 重型 汽門彈簧拆裝器

- > 用以拆卸安裝汽門彈簧



### EG37003

#### VALVE SPRING REMOVER / INSTALLER - BMW (N13/N20/N26/N55)

- > Applications: BMW N13, N20, N26, N55
- > Used to remove and install the pressure spring on intermediate lever.

#### 寶馬汽門彈簧拆裝器(N13/N20/N26/N55)

- > 適用: 寶馬 N13, N20, N26, N55
- > 用以拆卸與安裝在中間(槓)桿的壓縮彈簧器



### EG37004

#### VALVE PRESSURE SPRING REMOVER / INSTALLER - BMW(N42/N46)

- > Applications: BMW N42, N46
- > Special designed for removing and installing pressure spring on intermediate lever.

#### 寶馬汽門壓縮彈簧器(N42/N46)

- > 適用: 寶馬 N42, N46
- > 用以拆卸與安裝在中間(槓)桿的壓縮彈簧器



### EG37005

#### VALVE PRESSURE SPRING REMOVER / INSTALLER - BMW (N51/N52)

- > Applications: BMW N51, N52
- > Used to remove and install pressure spring on intermediate lever.

#### 寶馬汽門壓縮彈簧器(N51/N52)

- > 適用: 寶馬 N51, N52
- > 用以拆卸與安裝在中間(槓)桿的壓縮彈簧器



### EG37006

#### FUEL INJECTOR INSTALL & REMOVE TOOL - BMW (N20/N26/N55)

- > Applications: BMW N20, N26 and N55
- > For injector installation and removal.

#### 寶馬噴油嘴拆裝器(N20/N26/N55)

- > 適用: 寶馬 N20, N26, N55
- > 用以安裝與拆卸噴油器



### EG37007

#### FUEL INJECTOR INSTALL & REMOVE TOOL - BMW (N55)

- > Applications: BMW N55
- > For injector installation and removal.

#### 寶馬噴油嘴拆裝器(N55)

- > 適用: 寶馬 N55
- > 用以安裝與拆卸噴油器

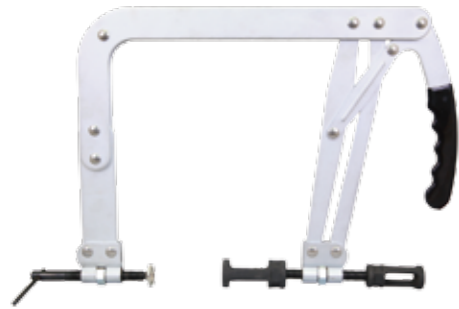

### EG37008 VALVE SPRING COMPRESSOR

- > Reversible jaw adaptor for multi-valve engines.
- > Capacity 45-145mm, throated clearance 250mm big window jaw adaptor for easy replacement of valve collects.
- > Dual size in 25mm and 30mm diameter.

#### 萬能凡爾鉗

- > 雙向的調整開口用於多汽門引擎
- > 容量45-145mm · 易於替換汽門油封 · 適用直徑25mm和30mm



### EG37009A VALVE SPRING COMPRESSOR

- > Used for Car & Motorcycle.
- > 5pcs pusher for fitting the valve spring correctly and easier to compress the valve spring.
- > Pusher size : 16mm, 19mm, 23mm, 25mm, and 30mm.

#### 螺桿型凡爾鉗

- > 適用於汽車與摩托車
- > 5件組接頭正確地裝配氣門彈簧 · 易於壓縮氣門彈簧 · 弓形結構以確保與氣門的同軸度
- > 接頭規格: 16mm, 19mm, 23mm, 25mm, 30mm



### EG37010 VALVE STEM SEAL PLIERS

- > Long neck designed to reach into confined area of the seal to grip it for removal.
- > Gripping serration in the allow them to grasp both original equipment & aftermarket seals regardless of the configuration.

#### 汽門油封拔取鉗

- > 鋸齒鉗口 · 延長前端設計 · 可深入受限的空間得以拔取汽門油封
- > 用以拆卸安裝汽車汽門油封和氣門彈簧



### EG40002 V-BELT PULLEY REMOVER – VW & AUDI

- > Models: VW Golf, Vento, Passat, Audi A3, Volvo
- > Special design to stop the pulley and remove the center bolts of generator.
- > Use with 17mm wrench.

#### 福斯&奧迪發電機皮帶盤拆卸器

- > 適用: 福斯-高爾夫、Vento、帕薩特、奧迪A3、富豪
- > 特殊設計用以停止皮帶盤滑動並拆卸發電機的中心螺栓 · 以移除V型皮帶盤
- > 搭配使用17mm扳手

### EG40002B 22PCS ALTERNATOR COMBINATION SET

- > Removes and installs press-on-type belt drive accessory pulleys.
- > Works with hand tools or an impact gun.
- > Interchangeable components to work on VW, Audi, Seat, Mercedes Benz, Renault, BMW, Ford, Fiat, etc.
- > Size:
  - 3 - Combined Socket for Alternator. T50 x 113mmL Socket; M10 x 113mmL Socket; 3/8Dr. x M10 x 80mmL W/ Ø14mm x 33T for Fiat.
  - 1 - Bit socket M10 x 140mmL.
  - 3 - Teeth Socket: 15mm Hex x 33 teeth x Ø19mm  
22mm Hex x 33 teeth  
15mm Hex x 33 teeth x Ø17.5mm
  - 2 - Hex Socket : 17mm、22mm.
  - 3 - Hex socket : 19 x 28 mm、21 x 28mm、22 x 28mm.
  - 1 - 35mm Round Socket W/4 pins.
  - 1 - 38mm Hex W/3Pins.
  - 1 - 1/2" Dr. SQ.(F) x 10mm Hex.(F) Bits Adaptor.
  - 1 - M10 x H12 x 64L bit.
  - 6 - 10mm(Hex Shank) x 75mmL CR-V bit: T40, T50, M8, M10, H8, H10.
  - Combined Socket for Alternator : 1/2" x 113mmL
  - T50 : BENZ A series
  - M10 : BENZ, BMW, AUDI, FORD, SKODA, VW etc.
  - 33 Teeth Socket : VW, AUDI.



#### 22件發動機皮帶盤維修組

- > 可更換組件適用: 福斯、奧迪、喜悅、賓士、雷諾、寶馬、福特、飛雅特等...
- > 搭配手工工具或氣動槍使用
- > 規格:
  - 3 - 綜合發電機套筒 : T50 x 113mm(長); M10 x 113mm(長)  
; 3/8Dr. x M10 x 80mm(長) / 外徑14mm x 33齒 · 適用飛雅特
  - 1 - 起子頭套筒 M10 x 140mm(長)
  - 3 - 套筒 : 15mm 內六角 x 33 齒 x 外徑19mm、22mm 內六角 x 33 齒、  
15mm 內六角 x 33 齒 x 外徑17.5mm
  - 2 - 內六角套筒 : 17mm、22mm
  - 3 - 內六角套筒 : 19 x 28 mm、21 x 28mm、22 x 28mm
  - 1 - 35mm 套筒 4 銷針
  - 1 - 38mm 內六角 3銷針
  - 1 - 1/2"Dr. 10mm 彈簧套頭
  - 1 - M10 x H12 x 64長 起子頭
  - 6 - 10mm x 75mm長 起子頭 : T40、T50、M8、M10、H8、H10
  - 綜合發電機套筒 : 1/2" x 113mm長
  - T50 : 賓士 A 系列
  - M10 : 賓士、寶馬、奧迪、福特、司科達、福斯等...
  - 33 齒套筒 : 福斯、奧迪



### EG40002C

#### 30PCS ALTERNATOR COMBINATION SET 30件發動機皮帶盤維修組

NO.(編號)	CONTENTS (產品)	SIZE (規格)	LENGTH (長度)	VEHICLE APPLICATION (適用車種)
#1	1/2"Dr. x T50 W/33Teeth Socket	17mm x 33T	110mmL	Mercedes A-Class (賓士 A系)
#2	1/2"Dr. x M10 W/33Teeth Socket	17mm x 33T	110mmL	VW, Audi, BMW, Ford, Skoda, Mercedes, Opel/Vauxhall, Porsche, Renault (福斯、奧迪、寶馬、福特、司科達、賓士、歐寶/沃克斯豪爾、保時捷、雷諾)
#3	H15 x 33 Teeth Socket	15mm x 33T	30mmL	Ford (福特)
#4	H22 x 33 Teeth Socket	22mm x 33T	30mmL	Renault, Mercedes (雷諾、賓士)
#5	H22 Socket	H22	30mmL	Universal (一般通用)
#6	H17 x 4 Pin Special Socket	H17 x 4 Pins	30mmL	Universal (一般通用)
#7	1/2"Dr. x H10 Bit adaptor	1/2"Dr. x 10mm		Universal (一般通用)
#8	H8 x H10 Bit	H8	75mmL	Universal (一般通用)
#9	H10 x H10 Bit	H10	75mmL	Universal (一般通用)
#10	M8 x H10 Bit	M8	75mmL	Universal (一般通用)
#11	M10 x H10 Bit	M10	75mmL	Renault (雷諾)
#12	T40 x H10 Bit	T40	75mmL	Universal (一般通用)
#13	T50 x H10 Bit	T50	75mmL	Universal (一般通用)
#14	M10 x H12 Bit	M10	64mmL	Renault, BMW, Ford, Mercedes, Porsche, Vauxhall, VAG (雷諾、寶馬、福特、賓士、保時捷、沃克斯豪爾、福斯系列)
#15	Special Socket	H22 x H28	30mmL	Porsche (保時捷)
#16	Special Socket	H19 x H28	30mmL	Universal (一般通用)
#17	1/2"Dr. x M10 Bit Socket	M10	140mmL	Universal (一般通用)
#18	3/8"Dr. x M10 W/31 Teeth Socket	14mm x 31T	85mmL	Fiat (飛雅特)
#19	Special Socket	H21 x H28	30mmL	Renault, BMW, Ford, Mercedes, Porsche, Vauxhall, VAG (雷諾、寶馬、福特、賓士、保時捷、沃克斯豪爾、福斯系列)
#20	Special Socket	H17	35mmL	Ford (福特)
#21	Special Socket	H38 x 3Pins	20mmL	Toyota (豐田)
#22	Special Socket	15mm x 33T	30mmL	Ford (福特)
#23	H10 x F H10 x 68L	H10 x F H10	68mmL	Toyota (豐田)
#24	T50 x H12 Bit	T50	64mmL	Mercedes-Benz A-Class (賓士 A系)
#25	Special Socket	H17 x H21	30mmL	Universal (一般通用)
#26	Special Socket	H15 x H28	30mmL	Universal (一般通用)
#27	3/8"Dr. Bit Adaptor x 10mm	3/8"Dr. x 10mm		Universal (一般通用)
#28	1/2"Dr. x T50 Bit Socket	T50	140mmL	Mercedes-Benz, Renault, Peugeot (賓士、雷諾、寶獅)
#29	1/2"Dr. x T50 Bit Socket	T50	200mmL	Mercedes-Benz, Renault, Peugeot (賓士、雷諾、寶獅)
#30	1/2"Dr. x M10 Bit Socket	M10	200mmL	Universal (一般通用)



### EG80001A 7PCS OXYGEN SENSOR SOCKET SET

- > For use on oxygen sensors on most modern cars.
- > This tool covers a wide variety of options and fits most heated and non-heated sensors.
- > SIEZ:
  - #1. 1/2"DR. x 29mm x 6PT x 90mm (L).
  - #2. 3/8"DR. x 7/8"(22mm) x 6PT x 90mm (L).
  - #3. 1/2"DR. x 27mm x 12PT x 78mm (L).
  - #4. 3/8"DR. x 7/8"(22mm) x 6PT x 80mm (L).
  - #5. 3/8"DR. x 1" & 1-1/16" x 74mm (L).
  - #6. 1/2"DR. x 7/8"(22mm) x 50mm (L).
  - #7. 3/8"DR. x 7/8"(22mm) x 30mm (L).

#### 7件含氧感知器套筒組

- > 含氧感知器套筒適用於大部分車輛，涵蓋適用大部分加熱和不加熱的感知器
- > 規格:
  - #1. 1/2"DR. x 29mm x 6角 x 90mm (長)
  - #2. 3/8"DR. x 7/8"(22mm) x 6角 x 90mm (長)
  - #3. 1/2"DR. x 27mm x 12角 x 78mm (長)
  - #4. 3/8"DR. x 7/8"(22mm) x 6角 x 80mm (長)
  - #5. 3/8"DR. x 1" & 1-1/16" x 74mm (長)
  - #6. 1/2"DR. x 7/8"(22mm) x 50mm (長)
  - #7. 3/8"DR. x 7/8"(22mm) x 30mm (長)



### EG80001-06 OXYGEN SENSOR L-SOCKET

- > Easily removes the oxygen sensor located in the exhaust manifold.
- > Needed for servicing today's computer-controlled vehicle systems.
- > Has 7/8" hex. 1/2" square drive (double square for easy access).
- > 1/2" DR. x 7/8"(22mm) x 50mm long.

#### 含感器拆除套筒-歐式L型

- > 易於拆卸於排氣歧管的含感器拆除套筒
- > 規格: 1/2"Dr. 7/8"(22mm) x 50mm長 · 1/2"接口 · 7/8"(22mm)內六角



### EG80001-08 1/2"DR. OXYGEN SENSOR SOCKET

- > 8mm slot for oxygen sensor on Japanese cars Ford, GM, Chrysler & other cars.
- > 1/2" Dr. 7/8" (22mm) x 90 mm long.

#### 1/2"DR. 含感器拆除套筒-日式

- > 適用於日系車、福特、通用汽車、克萊斯勒和其他汽車
- > 規格: 1/2"Dr. 7/8"(22mm) x 90mm長



## EG80003

### BMW SPARK PLUG SOCKET

- > 3/8"Dr. Spark Plug Socket, 12PT, 63L
- > Magnetic & brass

#### 寶馬 火星塞套筒(磁性 & 黃銅)

- > 規格: 3/8"Dr.火星塞套筒(薄型)、12角、63(長)·內部為磁性+黃銅
- > 3/8"Dr. 接口·套筒內部卡槽設計·以防止脫落·搭配扳手使用·內部為高強度磁鐵·結實耐用

ITEM NO.(編號)	SIZE(規格)	POINT(角)
EG80003-14M	14mm	12
EG80003-16M	16mm	12



## EG81002A

### INJECTOR EXTRACTOR SET

- > Applicable: BENZ CDI 611, 612, 613, 646, 647, 648 diesel engines.
- > This high quality tooling is designed for the removal of stuck and seized injectors.  
Slide hammer : 1.75Kgs. Length: 350mm(L)  
Adaptor: M17 x 1.0  
Adaptor: M27 x 1.0 for Bosch injector nozzle.  
Adaptor: puller w/M12 x 1.75

#### 賓士柴油噴油嘴拆卸器

- > 適用: 賓士 CDI 611, 612, 613, 646, 647, 648柴油引擎
- > 用以拆除被卡(咬)住的噴油器  
滑槌單重:1.75公斤 長度:350mm(長)  
轉接頭: M17 x 1.0  
轉接頭: M27 x 1.0 (用於博世的噴油嘴)  
轉接頭: M12 x 1.75



## EG82001-1

### GLOW-PLUG CONNECTOR PLIERS (ANGLED)

- > Models : Mercedes Benz, BMW, VW, Audi etc.
- > To remove stubborn and awkward to reach Glow-Plug connectors.
- > Version angled at 90°
- > Length : 235mm

#### 預熱塞連接器拆卸鉗

- > 適用: 賓士、寶馬、福斯、奧迪等...
- > 特殊角度設計·用以拆卸難以處理的預熱塞連接器·長度235mm



## EG82004A

### 4PCS VW & AUDI IGNITION COIL REMOVER TOOL SET

- > For Removing and installing ignition coils with power stage of injection engines on VW 8 and 12 CYL.
- > For Removing and installing ignition coils with power stage of injection engines on 5 and 6 CYL, VW GOLF, BORA, 4 AND 5 CYL. VW PASSAT, 6 CYL, VW SHARAN, TOUAREG, PHAETON.
- > For removing and installing ignition coils with power stage on VW POLO, GOLF 1.4, 1.6i, CADDY 1.4i, BORA 1.4, 1.6i, PASSAT, TOURAN 1.6i, PHAETON, TRANSPORTER T4.

#### 4件福斯&奧迪點火線圈拆卸器工具組

- > 用以拆卸與安裝福斯車系噴射引擎汽缸的點火線圈



## EG90001-1

### REACTION WRENCH

- > For Locking the pulley on the WATER-PUMP on VW POLO, GOLF, PASSAT, AUDI 80/A4
- > The 1/2" drive in the tools handle enables an extension of the tool by a ratchet.
- > Easy loosening of stubborn bolts on the water-pump pulley.
- > L: 250mm

#### 動力方向盤支撐扳手

- > 用以鎖定福斯 保羅, 高爾夫, 帕薩特, 奧迪 80/A4 水幫浦上的皮帶盤
- > 易於鬆開水幫浦皮帶盤上緊固的螺栓·長度:250mm



## EG90001-2

### REACTION WRENCH FOR EUROPEAN AUTOMOBILES

- > Applicable: VW, Audi
- > Safe locking of the water-pump pulley.
- > Easy loosening of stubborn bolts on the water-pump pulley.
- > Over length: 298mm
- > Width: 65mm

#### 水幫浦皮帶盤支撐扳手

- > 適用福斯·奧迪
- > 安全鎖定水幫浦皮帶盤
- > 易於鬆開水幫浦皮帶盤上緊固的螺栓·全長:298mm·寬度65mm



### EG90002 BENZ ENGINE FIXING SCREW WRENCH

- > For use on Mercedes BENZ W220, 210, 203, 219, 221, 211, 204
- > Removes the nuts from engine fixing screw without block.
- > Use with 3/8" Dr. wrench 100L

#### 賓士引擎腳扳手

- > 適用: 3/8"Dr.賓士 W220, 210, 203, 219, 221, 211, 204
- > 特殊角度設計易於拆卸螺帽·使用3/8"Dr.扳手100長

ITEM NO.(編號)	SIZE(規格)	POINT(角)
EG90002-16	16mm	12
EG90002-17	17mm	12



### EG90005 SPECIAL 6-POINTS SOCKET FOR NISSAN

- > 1/2" DR. Special 6-Points socket 125 x 38mm(L.)

#### 日產缸蓋螺絲套筒

- > 適用: 日產汽車E16引擎
- > 規格: 1/2" Dr. 特殊6角套筒 x 125 x 38mm (長)
- > 材質: 鉻釩鋼 表面處理磷酸錳黑



### UC60001 MULTI-PURPOSE INNER TIE ROD TOOL

- > The master tie rod tools easily replaces inner tie rod ends without removing the rack and pinion.
- > Capacity: 33-42mm

#### 方向機舵桿扳手(通用型)

- > 不用拆卸轉向器齒條與齒輪就可易於替換內橫拉桿球接頭
- > 規格: 33-42mm



### UC60002 MULTI-PURPOSE INNER TIE ROD TOOL

- > These tools are specially designed for the inner tie rods that are easily to replace inner tie rod ends, without removing the rack and pinion.
- > Capacity:33-42mm

#### 方向機舵桿扳手

- > 不用拆卸轉向器齒條與齒輪就可易於替換內橫拉桿球接頭
- > 搭配使用1/2"扳手·規格: 33-42mm·表面處理磷酸錳黑



### UC60003 DELUXE INNER TIE ROD TOOL

- > Use to remove and install inner tie rods on many GM and some Chrysler products that do not have a hex inner-end nut, but use 2 flats that measure 1-7/16" across.
- > Can also be used on all inner tie rods with 1-3/16" and 1-5/16" hex sizes.

#### 方向機連桿

- > 用以拆卸與安裝於通用汽車和克萊斯勒的內橫拉桿
- > 也可用於內橫拉桿1-3/16"與1-5/16"的內六角規格



### UC61001 BALL JOINT SOCKET FOR BENZ

- > Applicable: 163, 164 M/ML - Class front and rear axles.
- > Pin wrench socket 3/4" drive, to secure retaining ring for ball joint replacement.
- > This tool makes the fixing process faster and easier!

#### 賓士球接頭套筒

- > 適用: 賓士 163, 164 M/ML系列前後車輪軸
- > 使修理過程更快速容易



### UC61005 BALL JOINT SEPARATOR

- > Special design 2-stage operation suits most cars and light trucks ball joints in steering & suspension.
- > Tempered drop forged steel body and offset lever provide an excellent performance and long usage.
- > Offset lever permits maximum jaw openings in 30mm & 56mm.
- > Jaw open: 22mm.

#### 橫拉桿球頭拔卸器-歐規

- > 特殊設計適用於大部分車輛與小型卡車在轉向與懸吊系統的球接頭
- > 鍛造鋼·耐長期使用
- > 鉗開口: 22mm·偏移控制桿使之最大開口範圍: 30mm - 56mm
- > 可於空間受限內易於拆卸橫拉桿球頭



### UC61006 UNIVERSAL BALL JOINT EXTRACTOR

- > For splitting track-rod ends, anti-roll bar mountings, ball joints, etc.

#### 雙調整式橫拉桿球頭拔卸器

- > 用以分離橫拉桿·防傾桿安裝等...

ITEM NO.(編號)	A (鉗開口)	MAX. B (最大開口範圍)
UC61006-1	17mm	58mm
UC61006-2	22mm	62mm
UC61006-3	32mm	80mm
UC61006-4	45mm	90mm





### UC61007 BALL JOINT SEPARATOR

- > For splitting track-rod ends and ball joints.

#### 立式橫拉桿球頭拆卸器

- > 用以拆卸橫拉桿球頭

ITEM NO. (編號)	A (鉗開口)
UC61007-1	18mm
UC61007-2	23mm
UC61007-3	29mm
UC61007-4	40mm
UC61007-5	46mm



### UC61008A 5PCS SEPARATOR SET

- > With 5 popular "pickle forks" in a blow-molded case.
- > For removing shock absorber links, tie rods, and ball joints.
- > Also for general service on most cars and pickups.
- > SIZE:

- No. #1 size 12" long x 1-1/8" fork spread
- No. #2 size 12" long x 1-5/8" fork spread
- No. #3 size 12" long x 1-7/16" fork spread
- No. #4 size 16" long x 11/16" fork spread
- No. #5 size 16" long x 15/16" fork spread

#### 5件插式橫拉桿球接頭拆卸桿組

- > 為鉻鉚鋼材質，有五種規格，用以拆卸避震器鏈接、橫拉桿、球接頭
- > 適用汽車與小型(卡)車
- > 規格:

- No. #1 12" (長) x 1-1/8"
- No. #2 12" (長) x 1-5/8"
- No. #3 12" (長) x 1-7/16"
- No. #4 16" (長) x 11/16"
- No. #5 16" (長) x 15/16"



### UC61009 BALL JOINT SEPARATOR 立式橫拉桿球頭拆卸器(歐規)



ITEM NO. (編號)	JAWS OPEN (開口)	JAWS DEEP (開口深度)	APPLICABLE (適用車)
UC61009-1	23mm	25mm	Audi, BMW, Citroen, Ford, Mercedes, Opel, Peugeot, Renault, Rover, Saab, Volvo, VW, Japanische, Pkw, etc. 奧迪、寶馬、雪鐵龍、福特、賓士、歐寶、寶獅、雷諾、路華、紳寶、富豪、福斯等...
UC61009-2	28mm	25mm	Audi, A4, A6, A8, VW, Passat ab '97, etc. 奧迪 A4, A6, A8, 福斯, 帕薩特 ab'97等...



### UC61010-1 PITMAN ARM PULLER

- > For the safe easy removal of pitman arm assembly from compact automobiles.
- > Forged, heat-treated yoke with extra heavy center screw.
- > 1-1/16"(27mm) opening and 1-3/4"(45mm) pull.

#### 大車橫拉桿球頭拆卸器(小型)

- > 安全易於拆卸大車橫拉桿組件
- > 鍛造鋼，經熱處理加強中心螺桿強度
- > 開口:27mm、拉力:45mm



### UC61011-1 OUTER TIE ROD REMOVER

- > Works on imports and domestics; front or rear wheel drives; and castor stamped steel steering knuckles.
- > You can apply up to 5 tons of force to this puller to break the tie rod free from the steering knuckle without damaging either.
- > The special design of this puller also helps prevent the jaws from slopping on the steering knuckle when force is applied.

#### 兩爪活動橫拉桿拆卸器

- > 特別設計，有兩個活動型可以調節的拉爪，用以拆卸大部分車型的外橫拉桿



### UC61012A BENZ BALL JOINT INSTALLER (REMOVER)

- > Application : Benz W220 / W211 / W230
- > Special design to remove & install the ball joint without removing any parts.

#### 賓士A臂下球接頭拆裝器

- > 適用: 賓士 W220 / W211 / W230
- > 不用拆卸任何配件就可裝卸球接頭



### UC62001A MASTER BUSHING DRIVER, SEAL, AND BEARING INSTALLER SET

- > Set includes four drive handles and 11 adapters (most adapters have 3 or 4 size each)
- > Works in any industry, automotive...
- > Makes it easier to insert wheel bearing race and bushing. Seals without damage.

#### 凡爾培林油封銅襯塞入組

- > 適用於汽車
- > 更易於插入車輪培林座圈與軸承套，且不會造成油封損壞



## UC62002A

### UNIVERSAL REMOVE AND INSTALL SLEEVE KIT

- > For removing and installing bushings and bearings
- > Equipped with sleeve sizes from 34-66mm (ID) and 44-82mm (OD)
- > Includes 4 spindles with two 27mm hex nuts: M10 x P1.5, M12 x P2.0, M14 x P2.0 and M16 x P2.5
- > Provided with two step discs with two sides (A and B sides). Discs have tracks for fitting all sleeves, without needing several individual step discs
- > **Tool NOT designed to be used with an air/impact wrench**

#### 螺桿式鐵套拆裝器(通用型)

- > 用以安裝拆卸軸承套與培林·鐵套規格34-66mm(內徑)與44-82mm(外徑)
- > 四支螺桿450mm長·螺桿規格:M10 x P1.5, M12 x P2.0, M14 x P2.0, M16 x P2.5  
螺桿各有兩個27mm螺帽
- > 此工具不能與氣動扳手使用



## UC62003A

### 24PCS FWD FRONT WHEEL BEARING TOOL

- > Fit on most cars.
- > A great tool used to replace front wheel bearings without removing the steering knuckle & strut assembly.
- > As the spindle assemble isn't removed there is no need to align front end after the job is done.
- > Could be worked with shop press also.

#### 24件仰角培令拔卸器工具組

- > 適用於大部分汽車
- > 用以替換前輪仰角培令·而不需拆卸轉向節與支柱總成
- > 也可與壓機使用



## UC62004

### BEARING SEPARATOR

#### 培令拔卸器

- > 廣泛地適用於各種齒輪、軸承的拔卸操作

ITEM NO. (編號)	CAPACITY (使用範圍)	BOLT (螺栓規格)	BODY THREAD (主體螺紋)
UC62004-1	1 1/4" - 2 1/4". (30mm x 50mm)	9.5mm x L 125mm x 3/8" x 24UNF	3/8" x 16UNC
UC62004-2	2 1/4" - 3 1/2". (50mm x 75mm)	12.7mm x L 135mm x 1/2" x 20UNF	3/8" x 16UNC
UC62004-3	3" - 4 1/2". (75mm x 105mm)	16mm x L 165mm x 5/8" x 18UNF	1/2" x 13UNC
UC62004-4	4" - 6". (100mm x 150mm)	19mm x L 260mm x 3/4" x 16UNF	5/8" x 11UNC



## UC62005A

### BEARING SEPARATOR KIT

- > Pull out the bearing with the H-type beam and bolts.
- > Capacity: 3" - 4 1/2". (75mm - 105mm)
- > Bolt: 16mm x L 165mm x 5/8" x 18UNF
- > Body thread: 1/2" x 13UNC

#### 培令拔卸組

- > H型扁擔與螺柱用來拉拔培令
- > 適用範圍: 3" - 4 1/2". (75mm - 105mm)
- > 螺栓規格: 16mm x L 165mm x 5/8" x 18UNF
- > 主體螺紋: 1/2" x 13UNC
- > 產品規格: 大盤培令一個、2支主桿、2支長連接桿、1支中心頂桿(為兩用型頂桿頭)、1支H型扁擔



## UC62006A

### TWO SETS BEARING SEPARATOR KIT

- > Pull out the bearing with the H-type beam and bolts.
- > Capacity: 1 1/4" - 2 1/4". (30mm - 50mm)  
2 1/4" - 3 1/2". (50mm - 75mm)
- > Bolt: 9.5mm x L 125mm x 3/8" x 24UNF  
12.7mm x L 135mm x 1/2" x 20UNF
- > Body thread: 3/8" x 16UNC

#### 小型培令拔卸組-雙盤

- > H型扁擔與螺柱用來拉拔培令
- > 適用範圍: 1 1/4" - 2 1/4". (30mm - 50mm)  
2 1/4" - 3 1/2". (50mm - 75mm)
- > 螺栓規格: 9.5mm x L 125mm x 3/8" x 24UNF  
12.7mm x L 135mm x 1/2" x 20UNF
- > 主體螺紋: 3/8" x 16UNC
- > 產品規格: (雙盤)中、小盤培令各一個、2支加長主桿、2支短主桿、2支長連接桿、2支短連接桿、1支中心頂桿、1支H型扁擔



## UC62007A

### PROFESSIONAL WHEEL BEARING TOOL SET

- > Suitable for VW, Audi, Seat, Opel, BMW, etc.
- > For wheel bearing diameter 60mm - 85mm.
- > This tool set is for the precise, quick and professional removal and replacement of wheel bearings.
- > The design can prevent damage to the new wheel bearing because the press pieces enable safe and accurate centering and alignment when changing wheel bearings.

#### 車軸培林拆卸組

- > 適用: 福斯、奧迪、喜悅、歐寶、寶馬等...
- > 此工具用以精確快速且專業的拆卸替換車軸培林
- > 此設計可避免損害新的車輪培林·因替換車軸培林時按件能安全且精確的對準中心調整
- > 車軸培林直徑 60mm - 85mm





### UC62007B

#### PROFESSIONAL WHEEL BEARING TOOL SET FOR MERCEDES

- > Tool set for Mercedes e.g. 190 series (W201), A-Class (W168, W169), B-Class (W245), W124, C-Class (W202, W203), E-Class (W210), M-Class (W163, W164), S-Class (W140), V-Class (W639).
- > This tool can safe, quick and professional replacement and removal of wheel bearing.
- > Minimum working effort - high time saving
- > Simple and safe handling

#### 賓士 車軸培林拆卸組

- > 適用: 賓士 190 系列(W201), A系列 (W168, W169), B系列 (W245), W124, C系列 (W202, W203), E系列 (W210), M系列 (W163, W164), S系列 (W140), V系列 (W639).
- > 此工具能安全、快速且專業的拆卸替換車輪培林。簡單安全操作。節省時間、人力



### UC62007C

#### PROFESSIONAL WHEEL BEARING TOOL SET FOR VW / AUDI

- > Tool set for VW / Audi e.g. A3 (8L), Audi A4 (B5), A4 Quattro (B6) rear axle, A6 (4A, 4B), A8 (4D, 4E), TT (8N, 8J); VW Polo (6N), Golf (II, III, IV), Passat, Sharan, T4.
- > This tool can safe, quick and professional replacement and removal of wheel bearing.
- > Minimum working effort - high time saving
- > Simple and safe handling

#### 福斯/奧迪 車軸培林拆卸組

- > 適用: 福斯/奧迪 A3(8L), 奧迪 A4 (B5), A4 Quattro (B6) 後車軸, A6 (4A, 4B), A8 (4D, 4E), TT (8N, 8J); 福斯 保羅 (6N), 高爾夫 (II, III, IV), 帕薩特, Sharan, T4.
- > 此工具能安全、快速且專業的拆卸替換車輪培林。簡單安全操作。節省時間、人力



### UC62007D

#### PROFESSIONAL WHEEL BEARING TOOL SET FOR PEUGEOT / CITROEN / RENAULT

- > Tool set for Peugeot / Citroen / Renault
- > This tool can safe, quick and professional replacement and removal of wheel bearing.
- > Minimum working effort - high time saving
- > Simple and safe handling

#### 寶獅/雪鐵龍/雷諾 車軸培林拆卸組

- > 適用: 寶獅、雪鐵龍、雷諾汽車
- > 此工具能安全、快速且專業的拆卸替換車輪培林。簡單安全操作。節省時間、人力



### UC62009

#### THIN TYPE TWO JAWS BEARING REMOVER

- > Special design for removing the bearing in narrow space.
- > Working depth: 93mm
- > Jaws thickness : 1.5mm
- > Applicable bearing dimension : Ø30~90mm

#### 二爪薄型齒輪盤拔卸器

- > 特別設計用以在有限空間內拆卸培林。為滑動式的爪螺桿。以調節於適當位置固定
- > 使用深度93mm。爪的厚度1.5mm。適用培林規格: Ø30~90mm



### UC62011A

#### BUSH REMOVER / INSTALLER - BMW

- > Applications: BMW E38/E39/E53/E60/E61/E63/E64/E65/E66/E67/E70/F01/F02/F04/F07/F10/F11/F18
- > Removal and replacement tool for metallic bushes on rear axles.

#### 寶馬後仰角鐵套拆裝組

- > 適用: 寶馬 E38/E39/E53/E60/E61/E63/E64/E65/E66/E67/E70/F01/F02/F04/F07/F10/F11/F18
- > 用以拆卸替換後車軸的金屬軸承套



### UC62012A

#### SUSPENSION BUSH TOOL

- > Applicable: VW POLO 2002 later.
- > Special tool for replacing the front suspension bushes on VW Polo from 2002 onwards.

#### 福斯鐵套拆裝器(POLO)

- > 用以替換福斯 保羅 從2002年起的前懸吊軸承套



### UC62013A

#### VW, AUDI BUSH REMOVER / INSTALLER

- > Applicable: VAG series.
- > Special design to remove and install the bush.

#### 福斯,奧迪三角架鐵套拆裝器

- > 適用福斯車系列
- > 特殊設計用以拆卸與安裝軸承套



### UC69001 CV BOOT CLAMP PLIERS (EXTENSION)

- > Application: For AUDI, BMW, CHRYSLER, FORD, GM, HONDA, MAZDA, MERCEDES, NISSAN, VAUXHALL / OPEL, VW etc.
- > For all ear-type clamps
- > Designed to use with a 1/2"Dr. extension handle or torque wrench.

#### 防塵套束裝鉗(可延長)

- > 適用: 奧迪、寶馬、克萊斯勒、福特、通用汽車、本田、馬自達、賓士、日產、沃克斯豪爾/歐寶、福斯等...
- > 搭配使用1/2"Dr.接桿或扭力扳手



### UC69004 CV BOOT CLAMP PLIERS

- > For assembly of new stainless steel clamp-bands on drive-shafts where a torque setting is required.
- > The 3/8"Dr. torque wrench is ideal to provide the drive.
- > Made from CR-MO material, which is rigid and durable.

#### 防塵套束裝鉗

- > 使用在裝卸不銹鋼傳動軸防塵套的夾鉗
- > 使用3/8"Dr. 扭力扳手，以調整鉗口大小，使用方便
- > 為鉻鉚鋼材質，經久耐用，手柄表面防滑設計，使用更輕鬆



### UC69005 CV JOINT BANDING TOOL (WITH CUTTER)

- > Operated by hand or 1/2"Dr. wrench.
- > This tool can be easily removed by sliding sideways after winding has been completed.

#### 簡便型防塵套束裝器(附切刀)

- > 適用於大部分車系的防塵套束裝工具
- > 搭配使用1/2"Dr. 扳手操作



### UC70001 DECAGON SOCKET FOR BRAKE CALIPER PAD SCREW

- > Application: for Porsche Cayenne, Audi Q7
- > Use to remove socket 10 point
- > 3/8" DR. socket 9mm x 10PT x 30mm (L)

#### 保時捷-奧迪 卡鉗螺絲套筒

- > 適用: 保時捷 卡宴、奧迪 Q7
- > 用以拆卸10角螺絲套筒
- > 規格: 3/8"Dr. 套筒 9mm x 10角 x 30mm (長)



### UC70002A 3PCS BENDIX & LUCAS BRAKES SOCKET

- > Specialist socket set for Bendix and Lucas brakes
- > Specifications: 1/2" drive  
19mm pentagon socket, 14mm pentagon socket, 10mm pentagon bit

#### 3件剎車分泵組

- > 奔得士和盧卡斯 剎車專用套筒
- > 規格: 1/2"方孔 · 19mm五角套筒 · 14mm五角套筒 · 10mm五角起子頭套筒



### UC70003 DISC BRAKE PISTON SEPARATOR

- > Fits in brake caliper to push back pistons for new brake pads installation.
- > 2 - Spread Jaws, size: 115mm x 50mm x 6mm
- > 1 - 100mm (4") Sliding Bolt.
- > 1 - "T" type Sliding Bolt with 21mm Hex Head insert 1/2"SQ.

#### 碟式剎車調整器

- > 用以將新的剎車片安裝壓回活塞內
- > 規格: 2- 伸展顎, 尺寸: 115mm x 50mm x 6mm  
1- 100mm (4") 滑動螺栓  
1- T型滑動螺栓 21mm六角頭 鍍鍍螺栓



### UC70004A 18PCS BRAKE CALIPER SERVICE SET

- > Fits most cars.
- > Winds back brake piston for replacing brake pads.

#### 18件剎車卡鉗維修組

- > 適用大部分車輛剎車活塞的頂壓操作
- > 用以壓回剎車活塞，調節制動泵，更換剎車片
- > 為調剎車專用工具，鉻鋼材質，硬度高，不易變形，經精密加工，螺紋順滑
- > 操作簡單易懂，拆卸方便



### UC70004D 21PCS BRAKE CALIPER SERVICE SET

- > Fits most cars.
- > Winds back brake piston for replacing brake pads.

#### 21件剎車卡鉗維修組

- > 適用大部分車輛剎車活塞的頂壓操作
- > 用以壓回剎車活塞，調節制動泵，更換剎車片
- > 為調剎車專用工具，鉻鋼材質，硬度高，不易變形，經精密加工，螺紋順滑
- > 操作簡單易懂，拆卸方便

## UC72000

### IMPACT SOCKET FOR BENZ WHEEL SCREW

- > For easy removal of Mercedes-Benz wheels.
- > Socket specially designed with Mercedes wheel nut shapes.
- > No damage on wheel nut protection jacket.
- > 1/2"DR. X 17mm X 78mm(L)

#### 賓士汽動輪胎套筒

- > 套筒特別設計為賓士輪胎螺帽形狀，以易於拆卸賓士汽車輪胎
- > 為鉻鉬鋼材質，不會損壞輪胎螺帽保護套
- > 規格: 1/2"DR. X 17mm X 78mm(長)



## UC72001A

### 9PCS IMPACT WHEEL SCREW SOCKET SET

- > Suitable for American vehicles.
- > For removing wheel locks with impact/air wrench.
- > Chrome molybdenum

#### 9件汽動輪胎防盜螺絲拆除套筒

- > 適用於美國汽車
- > 需搭配汽動扳手以拆卸輪胎防盜螺絲
- > 鉻鉬鋼材質，表面處理磷酸鋁



## UC72003-3

### AIR CHUCKS

- > Length: 340mm
- > Input thread: 1/4"PT
- > Handle: Rubber

#### 輪胎打氣頭

- > 全長: 340mm
- > 進氣: 1/4"內牙
- > 握柄: 紅色



## UC79001

### BRAKE LINING GAUGE

- > Measures brake lining from 0 to 1/2" in 1/64" graduations.
- > Instructions:
  1. Apply jaws to brake shoe only as shown below. Keeping jaws on shoe, move the indicator arrow to "0", This will automatically subtract the shoe thickness from the total measurement.
  2. Apply jaws to shoe and lining as shown below. The arrow will indicate the amount of lining remaining.

#### 鼓式剎車片厚度檢測器

- > 用以檢測剎車片厚度



## UC79002

### TIRE TREAD AND BRAKE LINING GAUGE

- > Use to measure the amount of lining remaining on riveted and bonded drum shoes and disc brake pads.
- > Measures tire tread depth up to 9/16" in graduations of 1/64".
- > Checks pads without having to remove caliper completely.

#### 鼓式剎車片厚度及胎紋深度檢測器

- > 用以檢測剎車片厚度及胎紋深度

## UC79003

### 8PCS MANUAL BRAKE GAUGE SET

- > The brake gauge tool was designed to give customers an accurate measurement of how much brake lining is left without guess work.
- > Most state agencies require that the customer be notified of how much brake lining is left in order to suggest that the lining should be replaced.

#### Size:

- Red: 2,3mm – Bad
- Yellow: 4, 5, 6mm – Dangerous
- Green: 8, 10, 12mm – Good

#### 8件剎車片厚度量規

- > 可快速精確的檢測剎車片的厚度

#### 規格:

- 紅色片: 2,3mm, 表示剎車片必須更換
- 黃色片: 4,5,6mm 表示處於危險駕駛過程中，建議更換
- 綠色片: 8,10,12mm 表示剎車片是好的，處於良好的工作狀態中

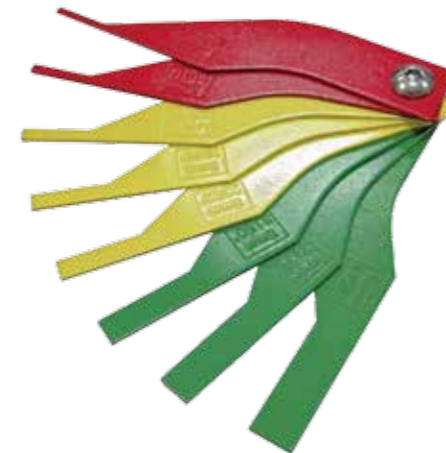

## UC80002A

### UNIVERSAL STRUT NUT TOOL SET

- > Suitable for most cars.
- > 39 turnbuckles with different sizes and designs to be applied to a wide selection of shock absorber caps.

#### SIZE:

- 2 - CENTRAL SOCKETS 5,10mm
- 9 - CENTRAL SOCKETS 4, 5.2, 6, 6.3, 7, 8, 9, 10, 12mm
- 4 - CENTRAL SOCKETS 5, 6, 7, 8mm
- 3 - CENTRAL SOCKETS 3, 3.5, 4mm
- 2 - CENTRAL SOCKETS T50, T60
- 1 - CENTRAL SOCKETS M12
- 4 - CENTRAL SOCKETS 8, 9, 10, 11mm
- 9 - CENTRAL SOCKETS 14, 16, 17, 18, 19, 21, 22, 24, 27mm
- 5 - CENTRAL SOCKETS 10.5, 12.5, 14, 14.5, 14.5mm

#### 39件綜合型避震器座套筒組

- > 適用大部份車輛
- > 39種不同規格尺寸設計的套筒應用於避震器上
- > 規格:

- 2個中央插座: 5, 10mm
- 9顆中央插座: 4, 5.2, 6, 6.3, 7, 8, 9, 10, 12mm
- 4顆中央插座: 5, 6, 7, 8mm
- 3顆中央插座: 3, 3.5, 4mm
- 2個中央插座: T50, T60
- 1個中央插座: M12
- 4顆中央插座: 8, 9, 10, 11mm
- 9個中央插座: 14, 16, 17, 18, 19, 21, 22, 24, 27mm
- 5個中央插座: 10.5, 12.5, 14, 14.5, 14.5mm





### UC80003

#### VW/AUDI STRUT NUT SOCKET

- > The 44mm long socket reaches down into the recess and fits the slot in the top of the nut.
- > Center bore allows you to hold the strut shaft from turning, and the 7/8"(21mm) hex can gripped with a wrench.

#### 福斯/奧迪 避震座拆除套筒

- > 用以拆裝大多數福斯/奧迪的避震器固定螺母
- > 翻轉時，中心孔可使你夾住支柱軸，使用扳手以拆卸頂部插槽中的固定螺帽
- > 為鉻鉚鋼，表面處理磷酸鋅黑



### UC80004

#### DECAGON SOCKET FOR HONDA CR-V

- > For removal and replacement of the rear trailing arm bolts on Honda CR-V.
- > 1/2"Dr. decagon socket 20mm X 38mm(L)

#### 本田CR-V十邊型套筒

- > 用以拆卸替換本田汽車後部(懸架)縱臂螺栓
- > 規格: 1/2"Dr. 10角套筒 20mm X 38mm(長) · 為鉻鉚鋼 · 表面處理磷酸鋅黑



### UC83001A

#### 8PCS INTERCHANGEABLE-FORK SPRING COMPRESSOR

- > Spring compressors are multi-application tools specifically.
- > Developed for modern macpherson suspensions, using a range of 3 sets of interchangeable forks.

#### 8件免拆式避震彈簧壓縮器

- > 避震彈簧壓縮器為多功能應用工具，有3套配置選擇，用以拆卸與安裝避震彈簧
- > 使用此工具時，可有效地減輕拆裝車子時減震彈簧的施力強度，操作簡便，具通用性與使用的安全性
- > 產品規格: 壓縮桿1支、壓盤(大、中、小型)各2個、調節器(鉤)1個
- > 適用: 奔馳、寶馬、豐田、福特、三菱、薩博、日產、本田、斯巴魯、沃爾沃、歐寶、保時捷、大眾、奧迪等車系的避震彈簧拆裝



### UC83002

#### COIL SPRING COMPRESSOR

- > The tool is designed for use in limited space under wheel arch.
- > Jaw design is fitting to wrap coil claws for safety.

#### 卷型彈簧壓縮器

- > 此工具設計為車輪罩(拱)下的有限空間內使用，鉤爪的設計能安全地扣住卷型彈簧
- > 專業用於機動維修時彈簧的壓緊，1/2"方孔，搭配1/2"驅動工具使用或套筒、扳手使用
- > 鉤爪與螺桿為鍛造鋼，以確保使用強度，螺桿為加寬螺紋設計，確保安全

ITEM NO.(編號)	LEAD SCREWS (L) (螺桿(長))	Max. jaw opening (最大爪開口)
UC83002-1	270mm	270mm
UC83002-2	300mm	300mm
UC83002-3	370mm	370mm



### UC83002A

#### COIL SPRING COMPRESSOR SET

- > The tools is designed for use in limited space under wheel arch.
- > Jaws design is fitting to wrap coil claws for safely.
- > Drop forged steel jaws & lead screws both heat treated.
- > Use with 1/2" drive ratchet. 270mm & 370mm lead screws coil spring compressors

#### 卷型彈簧壓縮器組

- > 此工具設計為車輪罩(拱)下的有限空間內使用，鉤爪的設計能安全地扣住卷型彈簧
- > 專業用於機動維修時彈簧的壓緊，1/2"方孔，搭配1/2"驅動工具使用或套筒、扳手使用
- > 鉤爪與螺桿為鋼鍛壓製造，以確保使用強度，270mm(長)與370mm(長)螺桿，為加寬螺紋設計，確保安全



### UC90001

#### NISSAN PENTAGON SOCKET

- > 1/2" DR. X 5T

#### 油底殼螺絲套筒

- > 放油螺絲專用工具
- > 規格: 五花型 · 五角寬齒套筒 1/2" DR. X 5T



### UC90002A

#### 21PCS 3/8"DR. OIL NUT SOCKET SET

- > Application: BMW, LANCIA, RENAULT, CITROEN, MAZDA, SAAB, FIAT, MERCEDES, TOYOTA, FORD, NISSAN, VAUXHALL/OPEL, HONDA, PEUGEOT, VOLKSWAGEN suitable for sump plugs on engine, gearbox and back axle.

- > Size: 3/8"Dr.  
Hex key socket: 8, 9, 10, 12, 13, 14, 17mm  
Square socket: 5/16", 3/8", 7, 8, 10, 11, 12, 13, 14mm  
Torx socket: T45  
Triangular socket: 10mm  
Square drive socket: 10mm  
Spline (tamper) socket: M16  
Sliding T-handle CR-V steel

#### 21件 3/8"DR.油底殼螺絲套筒組

- > 用於寶馬、蘭吉雅、雷諾、雪鐵龍、馬自達、紳寶、飛雅特、賓士、豐田、福特、日產、沃克斯豪爾/歐寶、本田、寶獅、福斯汽車引擎、變速箱、後車輪的油塞
- > 規格: 3/8"Dr.  
六角起子頭套筒: 8、9、10、12、13、14、17mm  
套筒: 5/16"、3/8"、7、8、10、11、12、13、14mm  
六角星形套筒: T45  
三角形套筒: 10mm  
四角套筒: 10mm  
十二角中孔起子頭套筒: M16  
三分滑桿 · 鉻鉚材質



**UC90004**  
VW OIL SCREW SOCKET M16H

- > Applicable: VW , AUDI oil screws.
- > Special design for using on narrow space.
- > Operated by 17 mm wrench.
- > Size: M16 tamper-proof.

**福斯變速箱機油套筒 M16H**

- > 適用: 福斯、奧迪的機油螺絲
- > 特別設計用於狹小空間
- > 操作搭配17mm扳手
- > 規格: M16中孔



**UC90005**  
SPECIAL 3-POINT STAR SOCKET FOR NISSAN OIL PUMP

- > For use on Nissan
- > Special 3-point star socket 1/2" Dr. 8 TS x 38mm(L)

**日產機油泵套筒**

- > 適用: 日產
- > 規格: 特殊三角套筒 1/2" Dr. 8 TS x 38mm(長) · 為鉻鋼 · 表面處理磷酸鋅黑



**UC91000**  
OIL FILTER MASTER PLIER

- > Suitable for installing, removing and tightening objects of any shape.
- > Locks onto the work with terrific grip.
- > Multi-purpose plier 2-1/8" to 4-5/8" (53mm - 118mm)range.
- > Chrome vanadium steel. Drop forged jaws, heat-treated. Nickel plated.

**機油濾清器鉗**

- > 用以安裝拆卸與緊定任何形狀的物體
- > 適用範圍53mm - 118mm
- > 為鉻鋼 · 鍛造經熱處理以加強強度 · 鍍鎳



**UC91002**  
TWO WAY OIL FILTER WRENCH

- > Special designed to install and remove the oil filter easily and quickly.
- > With pull spring to make it hold the filter easily.

**二爪正反轉機油心扳手**

- > 特殊設計以易於快速地安裝與拆卸機油濾清器
- > 使用範圍與使用扳手 · 如下表:

ITEM NO.(編號)	RANGE(範圍)	OPERATION WRENCH(使用扳手)
UC91002-1	60-80 mm	1/2" Dr. or 21mm wrench
UC91002-2	80-115mm	1/2" Dr. or 22mm wrench
UC91002-3	115-140mm	1/2" Dr. or 24mm wrench



**UC91010**  
OIL FILTER WRENCH

- > Slip joint design makes adjustment fast and easy.
- > Hardened drop forged CR-V steel tool removes stubborn filters 85m/m up to 115m/m.

**夾式機油心扳手**

- > 滑動接頭設計使調整快速容易
- > 鉻鋼材質 · 用以移除難以處理的濾清器 · 機油心扳手規格為115mm



**UC91012**  
3/8" DR. FLARE NUT WRENCH

- > Used for TOYOTA, HONDA bolts of fuel filter cup.
- > Special design with cover for holding the nut completely and prevent slipping.
- > Suit for narrow place.

**3/8"單開口扳手(加長型)**

- > 用於豐田、本田汽車燃油濾清器的螺栓
- > 可完全卡住螺帽並防滑 · 適用於狹小空間

ITEM NO.(編號)	SIZE(規格)	FULL LENGTH(全長)
UC91012-14	3/8" X 14mm	94mm
UC91012-17	3/8" X 17mm	97mm



**UC91013**  
BAND TYPE OIL FILTER WRENCH

- > Suitable for adjustable metal band and control knob makes grip tight.
- > For filters between 65mm to 155mm

**單速鋼帶機油芯扳手**

- > 用以調整金屬鬆緊帶與控制旋鈕使夾緊
- > 適用外徑65mm到155mm的機油芯

ITEM NO. (編號)	Ø(mm) (適用範圍)
UC91013-1	65 - 105 mm
UC91013-2	110 - 155 mm



**UC91014**  
BAND TYPE OIL FILTER WRENCH

- > Suitable for adjustable metal band and control knob makes grip tight.
- > For filters between 65mm to 155mm

**單速鋼帶機油芯扳手**

- > 用以調整金屬鬆緊帶與控制旋鈕使夾緊
- > 適用外徑65mm到155mm的機油芯

ITEM NO. (編號)	Ø(mm) (適用範圍)
UC91014-1	65 - 105 mm
UC91014-2	110 - 155 mm



### BD10001 ADJUSTABLE BODY BLADE

- > It could be adjusted radian by demand.
- > Use with 14" body blade.

#### 調整型鉸金銼刀架

- > 可依需求調整弧度
- > 配合14"(英吋)鉸金銼刀片



### BD10002 BODY BLADE

- > Length: 14"
- > TPI: 12TPI

#### 鉸金銼刀片

- > 長度:14"(英吋)
- > 每英吋12個牙數



### BD20001 LARGE PULL CLAMP WITH TOP PULL

- > Drop forged Chrome Molybdenum alloy steel for maximum strength.
- > Two-way pull operation.
- > Dual self-tightening serrated jaws for a positive grip.

#### 寬型張引夾(雙向)

- > 雙向拉力操作·雙自緊鋸齒狀鉗口(夾緊裝置)用以正夾住
- > 本體材質:SCM440 表面:五彩或磷酸鹽 螺栓材質:碳鋼 承載:3噸(直向),2噸(縱向)
- > 螺栓規格: 14m/mφ x 110m/m(長)



### BD20002 BOX CLAMP

- > Drop forged Chrome Molybdenum alloy steel for maximum strength.
- > Single-way pull operation.
- > Dual self-tightening serrated jaws for a positive grip.

#### 寬型張引夾(大小邊)

- > 單向拉力操作·雙自緊鋸齒狀鉗口(夾緊裝置)用以正夾住
- > 本體材質:SCM440 表面:五彩或磷酸鹽 螺栓材質:碳鋼 承載:3噸
- > 螺栓規格: 14m/mφ x 110 m/m (長)



### BD20003 BOX CLAMP

- > Drop forged Chrome Molybdenum alloy steel for maximum strength.
- > Single-way pull operation.
- > Dual self-tightening serrated jaws for a positive grip.

#### 寬型張引夾

- > 單向拉力操作·雙自緊鋸齒狀鉗口(夾緊裝置)用以正夾住
- > 本體材質:SCM440 表面:五彩或磷酸鹽 螺栓材質:碳鋼 承載:3噸
- > 螺栓規格: 14m/mφ x 120 m/m (長)



### BD20004 SMALL PULL CLAMP WITH TOP PULL

- > Drop forged Chrome Molybdenum alloy steel for maximum strength.
- > 44mm wide mouth with teeth
- > With top pull and 360 degree self tightening pull ring.
- > Dual self-tightening serrated jaws for a positive grip.
- > Ideal for work in tight areas.

#### 窄型張引夾(雙向)

- > 高拉力·360度自緊拉環·雙自緊鋸齒狀鉗口(夾緊裝置)用以正夾住·使用於緊密(密封)的區域·主要對車身進行夾持·在頭部增加吊環,固定方向後再進行拉伸
- > 本體材質:SCM440 表面:五彩或磷酸鹽 螺栓材質:碳鋼 承載:5噸(直向),2噸(縱向)
- > 螺栓規格: 16m/mφ x 70m/m(長)

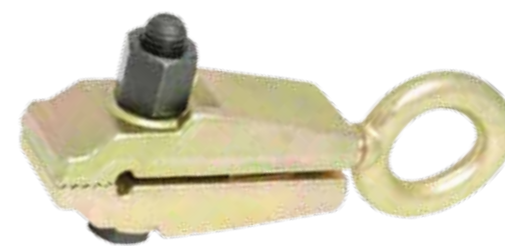

### BD20005 SMALL MOUTH PULL CLAMP

- > Drop forged Chrome Molybdenum alloy steel for maximum strength.
- > Single-way pull operation.
- > Dual self-tightening serrated jaws for a positive grip.
- > Ideal for work in tight areas.

#### 窄型張引夾

- > 單向拉力操作·雙自緊鋸齒狀鉗口(夾緊裝置)用以正夾住·使用於緊密(密封)的區域
- > 本體材質:SCM440 表面:五彩或磷酸鹽 螺栓材質:碳鋼 承載:5噸
- > 螺栓規格: 16m/mφ x 70m/m(長)



### BD20006 CHAIN JOINER SHORTENER

- > Use with 5/16" or 3/8" chains.
- > For use as a chain shortener or a chain connector.

#### 鍊條連接器

- > 搭配使用5/16"或3/8"的鍊條
- > 作為鍊條的縮短器或是鍊條連接器
- > 本體材質:SCM440 表面:五彩或磷酸鹽 鍊條材質:鉻鈦 承載:6噸

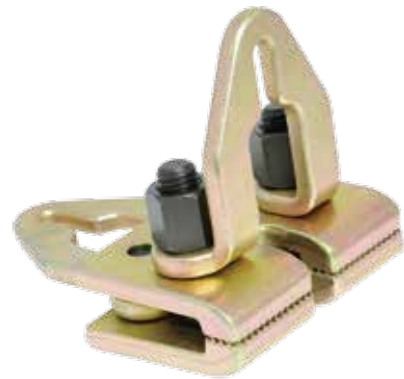

### BD20007

#### RAME RACK CLAMP (TWO-WAY)

- > Drop forged Chrome Molybdenum alloy steel for maximum strength.
- > Two-way pull operation.
- > Dual self-tightening serrated jaws for a positive grip.

#### 寬齒型張引夾(雙向)

- > 雙向拉力操作·雙自緊鋸齒狀鉗口(夾緊裝置)用以正夾住
- > 本體材質:SCM440 表面:五彩或磷酸鹽 螺栓材質:碳鋼 承載:5噸(直向),3噸(縱向)
- > 螺栓規格:14m/mφ x 73 m/m(長)

### BD20008

#### FRAME RACK CLAMP

- > Drop forged Chrome Molybdenum alloy steel for maximum strength.
- > Single-way pull operation.
- > Dual self-tightening serrated jaws for a positive grip.

#### 寬齒型張引夾

- > 單向拉力操作·雙自緊鋸齒狀鉗口(夾緊裝置)用以正夾住
- > 本體材質:SCM440 表面:五彩或磷酸鹽 螺栓材質:碳鋼 承載:5噸
- > 鋸齒長度:120mm
- > 螺栓規格:14m/mφ x 73 m/m(長)

### BD20009

#### HEAVY DUTY CLAMP

- > Drop forged Chrome Molybdenum alloy steel for maximum strength.
- > Single-way pull operation.
- > Dual self-tightening serrated jaws for a positive grip.

#### 重力型張引夾

- > 單向拉力操作·雙自緊鋸齒狀鉗口(夾緊裝置)用以正夾住·特殊設計於需強大拉力的情況
- > 本體材質:SCM440 表面:五彩或磷酸鹽 螺栓材質:碳鋼 承載:5噸
- > 螺栓規格:20m/mφ x 130m/m(長)

### BD20010

#### SLIDING HAMMER LOCKING PLIERS (LOCKING PULLER)

- > The Locking Puller can simply pull out any item you want to remove. 1.0 KG hammer sliding in the end will create a strong pulling force. In addition, the bolt can be removed quickly in the joint, separating the slide hammer and pliers, used as a rotating ring with locking pliers. It is possible to work in narrow places.
- > Applications:  
Pull out the rusty bolts / Pull out the staples / Pull out the nails / Steering wheel / Cotter pin / Dent puller / Fixing pins

#### 鉸金萬能鉗+衝鎚

- > 拉拔鉗可簡單地拉拔出所要拆卸的項目
- > 適用: 拔出生鏽的螺栓 / 拔出釘子 / 轉向盤 / 開口銷 / 凹痕拉馬 / 固定銷



### BD30001

#### W-TYPE AXIAL PLIER

- > W-TYPE Clamps lap joints allowing four consecutive spot welds without tool removal
- > Spot Welding. Auto-body repair work.
- > Size: 200mm Jaw Adjustment: 0-15mm

#### W型鉸金鉗

- > 在不移動工具的情況下·可連續焊接鉸件搭接處上四個焊點
- > 按壓把手·鉗口將自動張開·末端調節旋鈕·可調節鉗口張開的大小
- > 規格:200mm·適用範圍:0-15mm·鉗口材質:鉻鉬鋼·主體為鋼鐵·經熱處理

### BD30002

#### JJ-TYPE AXIAL PLIER

- > JJ-TYPE Clamps two flanged lapped or adjacent joints
- > Auto-body repair. Steel fabrication.
- > Size: 230mm Jaw Adjustment: 0-15mm

#### 雙J型鉸金鉗

- > 可以鉗住兩物件各有凸緣的連接處
- > 按壓把手·鉗口將自動張開·末端調節旋鈕·可調節鉗口張開的大小
- > 規格:230mm·適用範圍:0-15mm·鉗口材質:鉻鉬鋼·主體為鋼鐵·經熱處理



### BD30003

#### LL-TYPE AXIAL PLIER

- > LL-TYPE Clamps two butt or adjacent joints
- > Enables work in tight spots EVEN THROUGH HOLES.
- > Size: 215mm Jaw Adjustment: 0-10mm

#### 雙L型鉸金鉗

- > 可以鉗住兩物件各有凸緣的連接處·可用於狹小空間內操作
- > 按壓把手·鉗口將自動張開·末端調節旋鈕·可調節鉗口張開的大小
- > 規格:215mm·適用範圍:0-10mm·鉗口材質:鉻鉬鋼·主體為鋼鐵·經熱處理



### BD30004

#### J-TYPE AXIAL PLIER

- > J-TYPE Clamps two flanged lap joints
- > Enables work in tight spots EVEN THROUGH HOLES.
- > Size: 210mm Jaw Adjustment: 0-15mm

#### J型鉸金鉗

- > 可以鉗住兩物件各有凸緣的連接處·可用於狹小空間內操作
- > 按壓把手·鉗口將自動張開·末端調節旋鈕·可調節鉗口張開的大小
- > 規格:210mm·適用範圍:0-15mm·鉗口材質:鉻鉬鋼·主體為鋼鐵·經熱處理



### BD30005

#### L-TYPE AXIAL PLIER

- > Push Button Release: Easy and efficient ONE-HANDED releasing
- > Allow work in narrow areas.
- > Size: 195mm Jaw Adjustment: 0-18mm

#### L型鉸金鉗

- > 易於單手操作按壓把手上的按鈕·可用於狹小空間內操作
- > 按壓把手·鉗口將自動張開·末端調節旋鈕·可調節鉗口張開的大小
- > 規格:195mm·適用範圍:0-18mm·鉗口材質:鉻鉬鋼·主體為鋼鐵·經熱處理





### BD30006

#### L-TYPE AXIAL PLIER

- > Push Button Release: Easy and efficient ONE-HANDED releasing
- > Allow work in narrow areas.
- > Size: 195mm                      Jaw Adjustment: 0-18mm

#### L型鉸金鉗

- > 易於單手操作按壓把手上的按鈕·可用於狹小空間內操作
- > 按壓把手·鉗口將自動張開·末端調節旋鈕·可調節鉗口張開的大小
- > 規格: 195mm·適用範圍: 0-18mm·鉗口材質: 鉻鉬鋼·主體為鋼鐵·經熱處理



### BD30007

#### PLUGWELD PLIER WITH PAD

- > Copper alloy knurled swivel pad : Prevent burning through when plugwelding thin sheet metal
- > U-Shaped mobile jaw : Provide pressure around the spot to be welded properly.
- > Length: 10" (250mm)
- > Jaw Adjustment: 0-80mm

#### 薄板焊接鉗

- > 焊接時·可防止薄板焊穿
- > U型鉗口·可正確地焊接點
- > 規格為美規·長度:10" (250MM)·適用範圍:0-80mm
- > 為中碳鋼材質·經熱處理·表面: 鍍鎳



## 診斷工具 (壓力錶)

### DA10001A

#### 8PCS COOLING SYSTEM & RADIATOR CAP PRESSURE TESTER

#### 8件水箱測漏器



CONTENTS (產品規格)	APPLICATIONS (適用車種/用途)
System Testing Adapter NO.1	GM 4 cylinder (Buick, Chevrolet, Oldsmobile, Pontiac, Cadillac)
System Testing Adapter NO.2	Truck
System Testing Adapter NO.3	Mercedes-Benz, Ford, Chrysler, GM, Jeep, Truck, Peugeot.
System Testing Adapter NO.4	Acura, Dodge, Eagle, Geo, Honda, Isuzu, Lexus, Mazda, Mitsubishi, Suzuki, Toyota, Infiniti, Nissan, GM (Nova, Spectrum, Sprint), Peugeot, Ford, Chrysler.
System Testing Adapter NO.5	Toyota, Honda, Mitsubishi, Suzuki, Lexus, Chrysler, Acura, Dodge, Geo.
"2.3" Cap adapter	Testing the pressure cap
"4.5" Cap adapter	Testing the pressure cap
Cooling System pump	with pressure Gauge
1號測試轉接頭	通用汽車 4缸 (別克, 雪佛蘭, 奧斯摩比, 龐帝克, 凱迪拉克)
2號測試轉接頭	卡車
3號測試轉接頭	賓士, 福特, 克萊斯勒, 通用汽車, 吉普, 卡車, 寶獅
4號測試轉接頭	雅格, 道奇, Eagle, 吉優, 本田, 五十鈴, 凌志, 馬自達, 三菱, 鈴木 豐田, 英菲尼迪, 日產, 通用汽車 (Nova, Spectrum, Sprint), 寶獅, 福特, 克萊斯勒
5號測試轉接頭	豐田, 本田, 三菱, 鈴木, 凌志, 克萊斯勒, 雅格, 道奇, 吉優
"2.3"轉接頭蓋	測試壓力蓋
"4.5"轉接頭蓋	測試壓力蓋
冷卻系統泵浦	搭配壓力測試錶



### DA10001B

#### 22PCS COOLING SYSTEM & RADIATOR CAP PRESSURE TESTER

#### 22件水箱測漏器

CONTENTS (產品規格)	APPLICATIONS (適用車種/用途)
System Testing Adapter NO.1	GM 4 cylinder (Buick, Chevrolet, Oldsmobile, Pontiac, Cadillac)
System Testing Adapter NO.2	Truck
System Testing Adapter NO.3	Mercedes-Benz, Ford, Chrysler, GM, Jeep, Truck, Peugeot.
System Testing Adapter NO.4	Acura, Dodge, Eagle, Geo, Honda, Isuzu, Lexus, Mazda, Mitsubishi, Suzuki, Toyota, Infiniti, Nissan, GM (Nova, Spectrum, Sprint), Peugeot, Ford, Chrysler.
System Testing Adapter NO.5	Toyota, Honda, Mitsubishi, Suzuki, Lexus, Chrysler, Acura, Dodge, Geo.
System Testing Adapter NO.6	Buick, Chevrolet, Ford, Lincoln, GM, Opel, VW, Saab, Benz(ML-class), Jaguar Rover
System Testing Adapter NO.7	Jeep, Renault, Saab, Volvo, Audi, Citron, Flat, Peugeot, Alfa, Sterling, Peugeot.
System Testing Adapter NO.8	VW
System Testing Adapter NO.9	Audi(A4,A6,A8), VW(Passa 1997-2002, Golf, Jetta)
System Testing Adapter NO.10	BMW
System Testing Adapter NO.11	VW, Audi
System Testing Adapter NO.12	Ford, GM, International, Rover, Opel, Jaguar, BMW 245 (BMW up to 1987)
System Testing Adapter NO.13	Mercedes-Benz, Sedans with Threaded neck.
System Testing Adapter NO.14	Saab, Opel
"2.3" Cap adapter	Testing the pressure cap
"4.5" Cap adapter	Testing the pressure cap
Cooling System pump	with pressure Gauge
T Shape joint	5/16" 3/8"
Oil hose	5/16"
Oil hose	3/8"
Hose clamp	2 pcs
1號測試轉接頭	通用汽車4缸 (別克, 雪佛蘭, 奧斯摩比, 龐帝克, 凱迪拉克)
2號測試轉接頭	卡車
3號測試轉接頭	賓士, 福特, 克萊斯勒, 通用汽車, 吉普, 卡車, 寶獅
4號測試轉接頭	雅格, 道奇, 老鷹, 吉優, 本田, 五十鈴, 凌志, 馬自達, 三菱, 鈴木, 豐田, 英菲尼迪, 日產, 通用汽車 (Nova, Spectrum, Sprint), 寶獅, 福特, 克萊斯勒.
5號測試轉接頭	豐田, 本田, 三菱, 鈴木, 凌志, 克萊斯勒, 雅格, 道奇, 吉優
6號測試轉接頭	別克, 雪佛蘭, 福特, 林肯汽車, 通用汽車, 歐寶, 福斯, 薩博, 賓士(ML-class), 捷豹 陸華
7號測試轉接頭	吉普, 雷諾, 薩博, 富豪, 奧迪, 雪鐵龍, 飛雅特, 寶獅, 愛快羅密歐, 斯特林, 寶獅
8號測試轉接頭	福斯
9號測試轉接頭	奧迪(A4,A6,A8), 福斯(帕薩特 1997-2002, 高爾夫, Jetta)
10號測試轉接頭	寶馬
11號測試轉接頭	福斯, 奧迪
12號測試轉接頭	福特, 通用汽車, International, 路華, 歐寶, 捷豹, 寶馬245 (寶馬 up to 1987)
13號測試轉接頭	賓士, Sedans with Threaded neck
14號測試轉接頭	薩博, 歐寶
"2.3" 轉接頭蓋	測試壓力蓋
"4.5" 轉接頭蓋	測試壓力蓋
冷卻系統泵浦	搭配壓力測試錶
T型接頭	5/16" 3/8"
油管	5/16"
油管	3/8"
軟管夾	2件





### AC60002 FLEXIBLE HOSE CLAMP REMOVER

- > For removal of hose clamp on fuel, oil and water hose.
- > Hose clamp with flexible 600mm wire.
- > Convenient for working hidden areas and long distance.
- > Patented. Clamp open 10 - 63mm

#### 可彎式管束鉗

- > 用於燃油管、油管和水管的扣環替換
- > 拆卸管子上的扣環，兩端用力夾住，使扣環鬆開
- > 方便使用於較隱密的地方與長距離處
- > 彎線總長600mm，鉗開口：10 - 63mm



### AC60003 OIL COOLER LINE PLIER

- > Applications: BMW E46, E53, E65, E66, E85, R50, R53.
- > Release the hydraulic cooling lines that connect to the transmission.

#### 寶馬變速箱油冷卻管拆卸鉗

- > 適用：寶馬 E46, E53, E65, E66, E85, R50, R53.
- > 拆卸連接到該變速箱的液壓冷卻管
- > 可調整前段開口的螺絲，以改變使用的角度，不被空間侷限，能輕易完成拆卸工作



### AC60004 FUEL LINE CONNECTORS PLIERS

- > Use for VW-AUDI, FIAT, GM, OPEL, MERCEDES etc. E.G. Mercedes M-CLASS with petrol engines.
- > For removal and replacement of the connections on the in-line fuel filter.
- > Required when replacing the fuel filter or during engine repairs.

#### 汽油管接頭拆卸鉗

- > 適用福斯-奧迪、飛雅特、通用汽車、歐寶、賓士等...，如賓士M-CLASS汽油引擎
- > 用以拆卸替換管路上(串接的)燃油濾清器的引線
- > 用於替換燃油濾清器或引擎修護時



### AC60005A UNIVERSAL PINCHERS FOR HOSE CLIPS

- > Features heavy-duty construction with ratchet locking mechanism on most pliers.
- > CONTENTS:  
Hose clamp pliers  
Swivel jaw hose clamp pliers ( "+" slot)  
Swivel jaw hose clamp pliers  
Angled flat band hose clamp pliers  
Flat band hose clamp pliers  
Clip-R collar pliers  
Hose remover pliers

#### 7件束裝鉗組

- > 具棘輪鎖定裝置
- > 產品規格：  
可彎式喉式管束鉗  
旋轉鉗口式管束鉗(十字)  
旋轉鉗口式管束鉗  
彎型管束鉗  
直型管束鉗  
虎口式管束鉗  
軟管拆卸鉗



### AC60006A 3PCS FUEL & AC LINE COUPLING AND DISCONNECT TOOL SET

- > A. A/C FUEL LINE SPRING LOCK COUPLING TOOL
- > Applications:  
Ford 1981 to current, Chrysler LH series.  
For Ford sizes A=3/4", B=5/8", C=1/2", D=7/8".  
Easily releases locking couplings on fuel & air conditioning lines.  
**CAUTION Release system pressure before using this tool.**
- > B. FUEL LINE DISCONNECT TOOL
- > Applications:  
GM 1989 to current, Ford 1990 to current, Mazda some models 1990 to current.  
Chrysler fuel injection models (expect imports).  
Fit sizes E=3/8", F=5/16".  
Releases locking couplings on 5/16" and 3/8" fuel lines.  
**CAUTION Release system pressure before using this tool.**
- > C. FUEL LINE COUPLING TOOL
- > Fits 1990 - Current Ford Rangers & Explorers with 4.0L 6 cylinder engines.  
Separates fuel line from fuel pressure regulator on applications with quick disconnect style couplings.

#### 3件冷氣油管拆卸器組

- > 易於拆卸冷氣油管緊固的連接器
- > A. 為多功能四合一冷氣油管拆卸器，適用：福特1981年至今、克萊斯勒 LH系列  
適用福特規格：A=3/4", B=5/8", C=1/2", D=7/8"  
**警告：釋放系統壓力之前使用此工具**
- > B. 為多功能二合一冷氣油管拆卸器，適用：通用汽車1989年至今、福特1990年至今、馬自達1990年的一些型號至今、克萊斯勒燃油噴射車型  
二合一的規格為E=3/8", F=5/16"  
**警告：釋放系統壓力之前使用此工具**
- > C. 適用：1990年至今、福特流浪者&探索者的4.0L 6汽缸引擎  
用以分離燃油壓力調節器的燃油管為快速拆開型的連結器



### AC60007 7PCS A/C, FUEL LINE DISCONNECT SET

- > Includes seven tools for disconnecting spring couplings on Ford, GM, and Chrysler air conditioning lines.
- > Also works on fuel lines and can be used as push lock connectors on radiator and transmission lines.
- > Size include: 1/4", 5/16", 3/8", 1/2", 5/8", 3/4", 7/8".

#### 冷氣油管拆卸工具組

- > 主要用於快速拆裝冷氣油管與燃油管路
- > 有七種規格尺寸·用以拆卸福特、通用汽車和克萊斯勒冷氣油管的彈簧接頭
- > 規格: 1/4", 5/16", 3/8", 1/2", 5/8", 3/4", 7/8"

### AC60008A 21PCS FUEL & AIR CONDITIONING TOOL KIT

- > Contents:  
Spring lock couplings: 3/8", 1/2", 5/8", 3/4",  
Colour coded disconnecting set: 5/16", 3/8", 1/2", 5/8", 3/4", 7/8"  
Fuel line disconnect tool  
Ford oil cooling line disconnect tool  
- Ford fuel line coupling tool  
- Ford/GM quick disconnect tool  
- 7pc disconnecting set

#### 21件冷氣油管拆卸器組

- > 用以拆卸汽車冷氣油管工具
- > 產品規格:  
冷氣快速接頭拆卸器: 3/8", 1/2", 5/8", 3/4"  
冷氣油管拆卸器: 5/16", 3/8", 1/2", 5/8", 3/4", 7/8"  
燃油管路拆卸工具  
福特冷卻油管拆卸工具  
福特燃油管線接頭、福特/通用汽車快拆工具、7件拆線組

### AC60009 HOSE REMOVER PLIERS

- > For easy removal of 5/32" to 1/2" vacuum and fuel hoses.
- > Fit the jaws on the tube with black jaw on the tube and silver jaw on the hose.
- > Squeeze to push the hose off the tube.

#### 油管分離鉗

- > 易於拆卸5/32"至1/2"真空軟管和燃油管·使用時將鉗頭深入軟管內·夾住後拔出軟管
- > 擠推軟管以脫管·一邊黑色爪用於管上·一邊銀色爪用於軟管上
- > 產品體積小·輕巧方便攜帶·簡單操作·堅固耐用



### AC90001A 8PCS BENZ-BMW FAN CLUTCH WRENCH SET

- > A. Removes lock nuts on thermo-Viscous fans found on FORD BMW....many vehicles.(32mm)
- > B. Removes lock nuts on thermo-Viscous fans found on FORD Mercedes...many vehicles.(36mm)
- > C. Allows the technician to hold the water pump pulley in place while loosening the radiator fan.
- > D. To allow removal of the visco-coupling(viscous coupling) on the cooling fan.
- > E. Required to remove the radiator fan hub, the reaction spanner is bolted to the front face of the hub.
- > F. Special open-ended spanner to allow removal and replacement of the radiator fan hub. 65mm
- > G. The three-in-one design allows servicing three separate areas of repair. All of which require a specialty tool due to their confined locations.
- > H. Viscous fan nut wrench (46mm)

#### 8件賓士-寶馬風扇扳手組

- > 此風扇扳手·用於賓士、寶馬等...多種車輛
- A.拆卸風扇上螺帽的風扇扳手(32mm)·用於福特、寶馬等...多種車輛
- B.拆卸風扇上螺帽的風扇扳手(36mm)·用於福特、賓士等...多種車輛
- C.當在鬆開水箱風扇時·讓技師可夾住水泵皮帶輪
- D.可移除在冷卻風扇的黏性耦合器
- E.將三孔動力扳手固定於風扇殼上的螺栓得以拆卸
- F.特殊單開口扳手(65mm)可拆卸與替換散水箱風扇殼
- G.三合一的設計可維修三個不同的修復區域·因受限的空間而需要此特殊工具
- H.黏性風扇螺帽扳手(46mm)



### AC90002 RADIATOR CAP WRENCH

- > Quickly and safely removes all standard radiator caps.
- > Engage the wrench over the cap, press down and turn. easy!

#### 水箱蓋扳手

- > 快速安全地拆卸水箱蓋
- > 將扳手放在水箱蓋上·(向下)按下與轉動·易於操作

### AIW241A IMPACT WRENCH

- > Large torque.
- > Long Lasting.
- > Less vibration than single ring type.
- > Application: Especially in heavy-productive industries rattan, motor.
- Bolt Size Capacity (MM): M18~M20
- Working Torque: 450Nm/332ft-lb
- MAX. Torque: 600Nm/443ft-lb
- Free Speed: 6700 rpm
- Air Consumption: 297 l/min /10.5cfm
- Overall Length: 190mm/7.48inch
- Air Inlet: 1/4 PT
- Net Weight: 2.68KG/5.91lb
- Sound Level: 96dB(A)

#### 氣動扳手

- > 扭力大
- > 壽命長
- > 震動力較單環式小
- > 適用於汽機車、組立廠
- 螺栓規格: M18~M20
- 工作扭力: 450Nm/332ft-lb
- 最大扭力: 600Nm/443ft-lb
- 無負荷轉速: 6700 rpm
- 耗氣量: 297 l/min /10.5cfm
- 總長: 190mm/7.48inch
- 入氣接頭: 1/4 PT
- 淨重: 2.68KG/5.91lb
- 噪音值: 96dB(A)





## OT80003A

### 6PCS 3/8"DR. JOINTED GLOW PLUG SOCKET SET (WITH CLIP)

- > 6 - 3/8"DR. X 158mm
  - 8mm (Mercedes, Vauxhall / Opel, Fiat, Lancia)
  - 9mm (Vauxhall / Opel, Fiat)
  - 10mm (Mercedes, VAG)
  - 12mm (Mercedes, VAG, BMW, Peugeot, Renault)
  - 14mm (Renault, Citroen, Peugeot)
  - 16mm (Alfa Romeo, Fiat, Ford, Mazda, Citroen, Peugeot, Honda, Mercedes, Nissan, Vauxhall, Porsche)

### 6件預熱塞套筒組

- > 6件3/8"DR. X 158mm(長)預熱塞套筒組·規格如下:
  - 8mm (賓士, 沃克斯豪爾 / 歐寶, 飛雅特, 蘭吉雅)
  - 9mm (沃克斯豪爾 / 歐寶, 飛雅特)
  - 10mm (賓士, 福斯汽車集團)
  - 12mm (賓士, 福斯汽車集團, 寶馬, 寶獅, 雷諾)
  - 14mm (雷諾, 雪鐵龍, 寶獅)
  - 16mm (艾快羅密歐, 飛雅特, 福特, 馬自達, 雪鐵龍, 寶獅, 本田, 賓士, 日產, 沃克斯豪爾, 保時捷)



## OT90002A

### 23PCS TERMINAL RELEASE TOOL SET

- > For damage-free releasing of flat plug contacts.
- > Connection defects and corrosion can be repaired fast and easily.
- > Assortment with 23 parts for the universal application in the motor electric sector.

### 23件端子拆卸器組

- > 無損扁形插頭接觸點的釋放
- > 能快速容易地修復連接缺損和腐蝕
- > 23件組普遍適用於車用電機檢修工具



## OT90004A

### 10PCS CROWFOOT WRENCH

- > Designed to use on hard to reach fasteners.
- > Use on soft fittings such as brass and aluminum.
- > 3/8"DR. 6PT: 10-11-12-13-14-15-16-17-18-19mm

### 10件扳手頭組

- > 用以使用在難以到達的緊固件
- > 使用於如黃銅和鋁的裝配上
- > 規格: 3/8"DR. 6PT 10-11-12-13-14-15-16-17-18-19mm



## OT90006A

### 5PCS HOOK & PICK SET

- > Chrome vanadium steel / Heat-treated / Chrome plated
- > Set contains awl, hook tool, 45 degree & 90 degree bent tool.
- > Aluminum handle
- > Interchangeable handle

### 5件油封拉拔器組

- > 主要用於拉拔O型環(圈)等...
- > 產品規格主要為尖鑽、鉤具以及45度和90度彎型工具
- > 鉻釩鋼製/經熱處理/鍍鉻
- > 鋁合金手柄 / 可換式手柄

## OT90007A

### 4PCS MULTIPURPOSE SCRAPERS SET

- > This set includes a select on of multipurpose scrapers ideal for a variety of general automotive applications.
- > 3M Imperial wetordry paper A wt.
- > Short blades ideal for scraping hard-to-reach carbon deposits.
- > Long blade use to scrape engine blocks and heads.
- > Rigid carbon scrapers.

### 4件起子刮刀組

- > 此組包含多功能的刮刀·應用於各種一般通用的汽車
- > 短刮片用以刮除難以到達的積碳
- > 長刮片用以刮除引擎缸體與缸蓋
- > 為剛性碳刮刀



## OT90008

### SEAL PULLER

- > Easily removes grease and oil seals.
- > 2 tips for multiple applications.
- > Heavy-duty, heat-treated steel.
- > Red vinyl, non-slip handle.

### 油封拉拔器 (雙頭大型)

- > 易於拆卸潤滑脂與油封·2頭尖端為多功能應用
- > 經熱處理鋼材·紅色止滑握把



## OT90009

### AUTO PULLEY REMOVING WRENCH

- > Ideal for removing and assembling any type of grooved pulley for V-type belt.
- > Ideal for alternator and pump pulleys; but also essential for electric motors of compressors; washing machines; tool machines etc.
- > Also suitable to rotate the camshaft when timing the engine and to remove oil and gasoline filters.

### 皮帶盤束緊支檔扳手

- > 用以拆卸與安裝溝紋式皮帶盤的V型皮帶
- > 用於發電機幫浦皮帶盤
- > 拆除機油·汽油過濾器時轉動其凸輪軸





PERFECT TOOLS®

MADE IN TAIWAN

SINCE 2005



Tools best partner

GENERAL

通用工具



### OT90010A

#### 2PCS SCRAPER SET REVERSE & OFFSET

- > Reverse and offset scraper set for a variety of gasket scraping applications.
- > Offset scraper prevents damage to knuckles.
- > Reverse scraper gives more control with a pull back motion.
- > Correctly hardened steel blades.
- > Head size 25mm.

#### 2件多用途刮刀組

- > 反向和彎頭刮刀組應用於各種墊片刮
- > 彎頭刮刀防止損害轉向節
- > 反向刮刀多了回位移動調節
- > 為高碳鋼材質



### OT90011

#### SNAP RING PLIER

- > Heat-treated CR-MO steel plier
- > Operate both internal and external rings
- > Set includes 12 different size snap ring pliers

#### 雙用型O型環鉗

- > 用以安裝與拆卸簧環·內、外環均可適用
- > 為鉻鉬鋼材質·經熱處理
- > 三種鉗頭:直型(0度)、彎型(45度和90度)
- > 產品規格: 12件不同尺寸的O型環鉗

ITEM NO. (編號)	TIP ANGLE (鉗頭)	TIP DIA (INCH/mm) (鉗頭直徑) (英寸/公釐)	QTY/CTN (數量/箱)	G.W./KGS (毛重/公斤)	CUFT (材積)
OT90011-1	90°	0.038 / 1.0	120 PCS	14.00	1.9'
OT90011-2	45°	0.038 / 1.0	120 PCS	14.00	1.9'
OT90011-3	0°	0.038 / 1.0	120 PCS	14.00	1.9'
OT90011-4	90°	0.047 / 1.2	120 PCS	14.00	1.9'
OT90011-5	45°	0.047 / 1.2	120 PCS	14.00	1.9'
OT90011-6	0°	0.047 / 1.2	120 PCS	14.00	1.9'
OT90011-7	90°	0.070 / 1.8	120 PCS	21.50	3.1'
OT90011-8	45°	0.070 / 1.8	120 PCS	21.50	3.1'
OT90011-9	0°	0.070 / 1.8	120 PCS	21.50	3.1'
OT90011-10	90°	0.090 / 2.3	72 PCS	20.50	2.6'
OT90011-11	45°	0.090 / 2.3	72 PCS	20.50	2.6'
OT90011-12	0°	0.090 / 2.3	72 PCS	20.50	2.6'



### OT90011A

#### 10PCS SNAP RING PLIER SET

- > Cr-Mo steel, heat-treated
- > Comfortable insulated vinyl handles
- > Set includes 10 different size snap ring pliers

#### 10件雙用型O型環鉗組

- > 用以安裝與拆卸簧環·內、外環均可適用
- > 為鉻鉬鋼材質·經熱處理
- > 產品規格: 10件不同尺寸的O型環鉗
- > 舒適好握膠柄

PLIER SIZE (LENGTH) (O型環鉗 (長度))	TIP DIA (INCH/mm) (鉗頭直徑) (英寸/公釐)
5 1/2" (Bend)彎型	0.038 / 1.0
6" (Straight) 直型	0.038 / 1.0
5 1/2" (Bend)彎型	0.047 / 1.2
6" (Straight) 直型	0.047 / 1.2
7 1/2" (Bend)彎型	0.070 / 1.8
8" (Straight) 直型	0.070 / 1.8
8 1/2" (Bend)彎型	0.090 / 2.3
9" (Straight) 直型	0.090 / 2.3
5" Hook tool	
5" Pick tool	



### OT93001

#### REMOVAL THE IGNITION SWITCH RETAINING RING FOR BENZ

- > Applications: BENZ W129 · W140 · W202 · W201 · W220 · W203 · W209 · W211 · W204
- > Use for removal replacement of the ignition switch retaining ring.

#### 賓士外鎖套拆裝工具

- > 適用: 賓士 W129 · W140 · W202 · W201 · W220 · W203 · W209 · W211 · W204
- > 用以拆卸更換賓士點火開關裝置



### OT93002

#### CLIP REMOVAL PLIERS

- > Use the head of the plier to insert the plastic button of the plate.
- > Then push the tool and remove the plastic button.
- > It is save manpower with pull straight.

#### 下壓式膠扣鉗

- > 用於汽車門面板與其他部分的拔取
- > 使用膠扣鉗頭插入車板的塑膠扣·推壓進膠扣鉗以拆卸塑膠扣·節省人工操作拉力



### OT93003A

#### 5PCS HANDY REMOVER SET

- > For plastic upholstery fasteners.
- > Place tool under edge of door panel and insert into fastener as fast as possible, and then simply pry up.
- > Large support area to protect clips and pad.

#### 5件塑鋼撬棒組

- > 用於(車身)塑料內飾的緊固件
- > 放置塑鋼撬棒於門板端下並盡快速地插入緊固件內·以簡單地撬起物件



Tools best partner



**PT-S4140A-BS1**  
1/4"+3/8"+1/2" DR. 140PCS SOCKET SET  
1/4"+3/8"+1/2" DR. 140件套筒扳手組

- 11-1/4" SOCKET 4-4.5-5-5.5-6-7-8-9-10-11-12MM
- 10-1/4" SOCKET 5/32" - 3/16" - 7/32" - 1/4" - 9/32" - 5/16" - 11/32" - 3/8" - 7/16" - 1/2"
- 5-1/4" DEEP SOCKET 8-9-10-12-13MM
- 5-1/4" STAR SOCKET E4-E5-E6-E7-E8
- 7-3/8" SOCKET 13-14-15-16-17-18-19MM
- 6-3/8" SOCKET 9/16" - 5/8" - 11/16" - 3/4" - 13/16" - 7/8"
- 3-3/8" DEEP SOCKET 14-15-17MM
- 6-3/8" STAR SOCKET E10-E11-E12-E14-E16-E18
- 7-1/2" SOCKET 20-21-22-24-27-30-32MM
- 4-1/2" SOCKET 15/16" - 1" - (1-1/16") - (1-1/4")
- 3-1/2" STAR SOCKET E20-E22-E24
- 4-1/2" IMPACT SOCKET 17-19-21-23MM
- 1/4" BIT COUPLE 1/4"DR X 1/4"BIT
- 1/4" 3/8" 1/2" RATCHET HANDLE
- 1/4" 3/8" 1/2" UNIVERSAL JOINT
- 1/4" 3/8" 1/2" EXTENSION BAR 100MM - (75MM - 150MM) - (125MM - 250MM)
- 1/4" MULTI-SPANNER HANDLE 150MM
- 1/4" BIT SOCKET PH:0-1-2-3 SL:4-5.5-6.5 HEX:3-4-5-6 TX:T7-T8-T9-T10-T15-T20-T25-T27-T30-T40
- 3/8" MULTI-SOCKET ADAPTOR 3/8" F X 1/2" M
- 3/8" SOCKET ADAPTOR 3/8" F X 1/4" M
- 1/2" SPARK PLUG SOCKET 16MM - 21MM
- COMBINATION WRENCH 8-9-10-11-12-13-14-17-18-19MM
- BITS

2 SETS/CTN  
G.W.: 19.60 KGS  
CUFT : 1.3'



**PT-S248A-BS1**  
1/4" DR. 48PCS SOCKET SET  
1/4" DR. 48件套筒扳手組

- 13-1/4" SOCKET 4-4.5-5-5.5-6-7-8-9-10-11-12-13-14MM
- 1/4" BIT COUPLE 1/4"DR X 1/4"BIT
- 1/4" RATCHET HANDLE
- 1/4" UNIVERSAL JOINT
- 1/4" SLIDING T-BAR
- 1/4" EXTENSION BAR 50MM - 100MM
- 1/4" FLEXIBLE EXTENSION BAR 150MM
- 1/4" MULTI-SPANNER HANDLE 150MM
- 1/4" BIT SOCKET PH:1-2-3 PZ:1-2-3 SL:4-5.5-7 HEX:3-4-5-6-7-8 TX:T8-T10-T15-T20-T25-T30-T40
- 3/8" SOCKET ADAPTOR 3/8" F X 1/4" M
- HEX KEY WRENCH 1.27-1.5-2-2.5MM

15 SETS/CTN  
G.W.: 20.60 KGS  
CUFT : 1.35'



**PT-S330A-BS1**  
3/8" DR. 30PCS SOCKET SET  
3/8" DR. 30件套筒扳手組

- 3/8" 18 - SOCKET 6-7-8-9-10-11-12-13-14-15-16-17-18-19-20-21-22-24 MM
- 6 - DEEP SOCKET 8-9-10-12-13-14 MM
- 2 - SPARK PLUG SOCKET 16MM - 21MM
- 1 - RATCHET HANDLE
- 1 - UNIVERSAL JOINT
- 2 - EXTENSION BAR 75MM - 150MM

6 SETS/CTN  
G.W.: 16.40 KGS  
CUFT : 1.36'



### STRENGTHEN BAR

Features  
Enhance the box edge hardness & attractive.



### PLASTIC PIN

The plastic pin design  
Prolong lifetime.  
Make the box to stand.  
It's more better than the traditional design.



### PT-S217E-BS1

1/4" DR. 17PCS SOCKET SET

1/4" DR. 17件套筒扳手組

- 12 - SOCKET 4-4.5-5-5.5-6-7-8-9-10-11-12-13 MM
- 1 - RATCHET HANDLE
- 1 - UNIVERSAL JOINT
- 1 - SLIDING T-BAR
- 1 - EXTENSION BAR 50MM
- 1 - MULTI-SPANNER HANDLE 150MM

20 SETS/CTN  
G.W.: 15.02 KGS  
CUFT : 1.27'



### PT-S236A-BS1

1/4" DR. 36PCS SOCKET SET

1/4" DR. 36件套筒扳手組

- 10 - 1/4" SOCKET 4-5-5.5-6-7-8-10-11-12-13MM
- 6 - 1/4" DEEP SOCKET 6-7-8-10-12-13MM
- 1/4" BIT COUPLE 1/4"DR X 1/4"BIT
- 1/4" RATCHET HANDLE
- 1/4" UNIVERSAL JOINT
- 1/4" EXTENSION BAR 50MM - 100MM
- 1/4" BIT PH:1-2 PZ:1-2 SL:4-5.5 HEX:5-6 TX:T10-T15-T20
- 3/8" MULTI-SOCKET ADAPTOR 3/8" F X 1/4" M  
HEX KEY WRENCH 1.5-2-2.5MM

20 SETS/CTN  
G.W.: 21.30 KGS  
CUFT : 1.75'



### PT-S239A-BS1

1/4" DR. 39PCS SOCKET SET

1/4" DR. 39件套筒扳手組

- 10 - SOCKET 4-5-6-7-8-9-10-11-12-13 MM
- 3 - DEEP SOCKET 8-10-12 MM
- 1 - RATCHET HANDLE
- 1 - UNIVERSAL JOINT
- 2 - EXTENSION BAR 50MM - 150MM
- 1 - FLEXIBLE EXTENSION BAR 150MM
- 16 - BIT SOCKET PH:1-2-3 SL:4-4.5-7 HEX:3-4-5-6  
TX:T10-T20-T25-T27-T30-T40
- 4 - HEX KEY WRENCH 1.27-1.5-2-2.5MM

20 SETS/CTN  
G.W.: 25.04 KGS  
CUFT : 1.75'



### PT-S258A-BS1

1/4" DR. 58PCS SOCKET SET

1/4" DR. 58件套筒扳手組

- 12 - SOCKET 4-4.5-5-5.5-6-7-8-9-10-11-12-13MM
- 1 - BIT COUPLE 1/4"DR X 1/4"BIT
- 1 - RATCHET HANDLE
- 1 - UNIVERSAL JOINT
- 1 - SLIDING T-BAR
- 1 - EXTENSION BAR 50MM
- 1 - MULTI-SPANNER HANDLE 150MM
- 40 - BIT PH:0-1-2-2-3 PZ:0-1-2-2-3 SL:2.5-3-4-4.5-5-5.5-6-6.5-7-8  
HEX:1.5-2-2.5-3-4-5-5.5-6-7-8  
TX:T7-T8-T10-T15-T20-T25-T27-T30-T35-T40

20 SETS/CTN  
G.W.: 20.21 KGS  
CUFT : 1.27'



### PT-S325A-BS1

3/8" DR. 25PCS SOCKET SET

3/8" DR. 25件套筒扳手組

- 17 - 3/8" SOCKET 6-7-8-9-10-11-12-13-14-15-16-17-18-19-20-21-22 MM
- 3/8" SPARK PLUG SOCKET 16MM - 21MM
- 3/8" RATCHET HANDLE
- 3/8" UNIVERSAL JOINT
- 3/8" EXTENSION BAR 75MM - 150MM - 250MM
- 1/2" MULTI-SOCKET ADAPTOR 1/2" F x 3/8" M

6 SETS/CTN  
G.W.: 16.00 KGS  
CUFT : 1.36'



**PT-S341A-BS1**

3/8" DR. 41PCS SOCKET SET  
3/8" DR. 41件套筒扳手組

- 18- SOCKET 6-7-8-9-10-11-12-13-14-15-16-17-18-19-20-21-22-24MM
- 6- DEEP SOCKET 8-9-10-12-13-14MM
- SPARK PLUG SOCKET 16MM - 21MM
- RATCHET HANDLE
- UNIVERSAL JOINT
- EXTENSION BAR 75MM - 150MM
- COMBINATION WRENCH 7-8-9-10-11-12-13-14-15-16-17MM

6 SETS/CTN  
G.W.: 20.33 KGS  
CUFT : 1.36'



**PT-S365A-BS1**

3/8" DR. 65PCS SOCKET SET  
3/8" DR. 65件套筒扳手組

- BIT COUPLE 1/4"DR X 1/4"BIT
- BIT PH:0-1-2-2-3 PZ:0-1-2-2-3 SL:2.5-3-4-4.5-5-5.5-6-6.5-7-8  
HEX:1.5-2-2.5-3-4-5-5.5-6-7-8  
TX:T7-T8-T10-T15-T20-T25-T27-T30-T35-T40
- 17- SOCKET 6-7-8-9-10-11-12-13-14-15-16-17-18-19-20-21-22 MM
- SPARK PLUG SOCKET 16MM - 21MM
- RATCHET HANDLE
- UNIVERSAL JOINT
- EXTENSION BAR 75MM-150MM
- SOCKET ADAPTOR 3/8" F x 1/4" M

6 SETS/CTN  
G.W.: 15.25 KGS  
CUFT : 1.36'



**PT-S422B-BS1**

1/2" DR. 22PCS SOCKET SET  
1/2" DR. 22件套筒扳手組

- 15- SOCKET 8-10-11-12-13-14-15-17-18-19-22-24-27-30-32 MM
- MULTI-SOCKET ADAPTOR 3/8" F x 1/2" M
- SPARK PLUG SOCKET 16MM - 21MM
- RATCHET HANDLE
- UNIVERSAL JOINT
- EXTENSION BAR 125MM - 250MM

6 SETS/CTN  
G.W.: 22.60 KGS  
CUFT : 1.36'



**PT-S424C-BS1**

1/2" DR. 24PCS SOCKET SET  
1/2" DR. 24件套筒扳手組

- 19-SOCKET 8-10-11-12-13-14-15-16-17-18-19-20-21-22-23-24-27-30-32MM
- 1 - RATCHET HANDLE
- 1 - UNIVERSAL JOINT
- 1 - F-HANDLE
- 2 - EXTENSION BAR 125MM - 250MM

5 SETS/CTN  
G.W.: 22.33 KGS  
CUFT : 1.26'



**PT-S426A-BS1**

1/2" DR. 26PCS SOCKET SET  
1/2" DR. 26件套筒扳手組

- 20-SOCKET 8-9-10-11-12-13-14-15-16-17-18-19-20-21-22-23-24-27-30-32MM
- 1 - SPARK PLUG SOCKET 21MM
- 1 - RATCHET HANDLE
- 1 - UNIVERSAL JOINT
- 1 - SLIDING T-BAR
- 2 - EXTENSION BAR 125MM - 250MM

5 SETS/CTN  
G.W.: 23.49 KGS  
CUFT : 1.26'



**PT-S429A-BS1**

1/2" DR. 29PCS SOCKET SET  
1/2" DR. 29件套筒扳手組

- 15- SOCKET 8-10-11-12-13-14-15-17-18-19-22-24-27-30-32MM
- MULTI-SOCKET ADAPTOR 3/8" F X 1/2" M
- SPARK PLUG SOCKET 16MM - 21MM
- RATCHET HANDLE
- UNIVERSAL JOINT
- EXTENSION BAR 125MM - 250MM
- COMBINATION WRENCH 10-11-12-13-14-15-17MM

5 SETS/CTN  
G.W.: 21.48 KGS  
CUFT : 1.15'



**PT-S472A-BS**

1/4" + 1/2" DR. 72PCS SOCKET SET  
1/4" + 1/2" DR. 72件套筒扳手組

- 9- SOCKET 4-5-6-7-8-9-10-11-12MM
- 9- SOCKET 13-14-15-16-17-19-21-22-24MM
- BIT COUPLE 1/4"DR X 1/4"BIT
- RATCHET HANDLE
- EXTENSION BAR 50MM - 100MM - 125MM
- BIT PH:0-1-2-2-3 PZ:0-1-2-2-3 SL:2.5-3-4-4.5-5-5.5-6-6.5-7-8  
HEX:1.5-2-2.5-3-4-5-5.5-6-7-8  
TX:T7-T8-T10-T15-T20-T25-T27-T30-T35-T40
- UNIVERSAL JOINT
- COMBINATION WRENCH 10-11-12-13-14-15-17MM

6 SETS/CTN  
G.W.: 20.66 KGS  
CUFT : 1.36'



**PT-S473B-BS1**

1/4" + 1/2" DR. 73PCS SOCKET SET  
1/4" + 1/2" DR. 73件套筒扳手組

- 13- SOCKET 4-4.5-5-5.5-6-7-8-9-10-11-12-13-14MM
- 20- SOCKET 8-9-10-11-12-13-14-15-16-17-18-19-20-21-22-23-24-27-30-32MM
- RATCHET HANDLE
- UNIVERSAL JOINT
- EXTENSION BAR 50MM - 250MM
- FLEXIBLE EXTENSION BAR 150MM
- MULTI-SPANNER HANDLE 150MM
- (8MM) BIT
- PH:3-4 PZ:3-4 SL:8-10-12 HEX:8-10-12-14 TX:T30-T40-T45-T50-T55
- MULTI-SOCKET ADAPTOR 3/8" F X 1/2" M
- BIT COUPLE 1/2"DR X 5/16"BIT
- COMBINATION WRENCH 8-9-10-11-12-13-14-15-17-19-22MM
- HEX KEY WRENCH 1.5-2-2.5MM

4 SETS/CTN  
G.W.: 22.44 KGS  
CUFT : 1.78'



PERFECT TOOLS®

SINCE 2005



Tools best partner

SOCKET WRENCH SET

套筒扳手組

### PT-S497A-BS1

1/4" + 1/2" DR. 97PCS SOCKET SET

1/4" + 1/2" DR. 97件套筒扳手組



- 13-1/4" SOCKET 4-4.5-5-5.5-6-7-8-9-10-11-12-13-14MM
- 8-1/4" DEEP SOCKET 6-7-8-9-10-11-12-13MM
- 20-1/2" SOCKET 8-9-10-11-12-13-14-15-16-17-18-19-20-21-22-23-24-27-30-32MM
- 4-1/2" DEEP SOCKET 14-15-17-19MM
- 1/4" 1/2" RATCHET HANDLE
- 1/4" 1/2" UNIVERSAL JOINT
- 1/4" SLIDING T-BAR
- 1/4" 1/2" EXTENSION BAR 50MM - 100MM - 125MM - 250MM
- 1/4" FLEXIBLE EXTENSION BAR 150MM
- 1/4" MULTI-SPANNER HANDLE 150MM
- 1/4" BIT SOCKET PH:1-2 PZ:1-2 SL:4-5-5-7 HEX:3-4-5-6 TX:T8-T10-T15-T20-T25-T27-T30
- 3/8" MULTI-SOCKET ADAPTOR 3/8" F X 1/2" M
- 5/16" (8MM) BIT
- PH:3-4 PZ:3-4 SL:8-10-12 HEX:8-10-12-14 TX:T30-T40-T45-T50-T55
- 1/2" SPARK PLUG SOCKET 16MM - 21MM
- 1/2" BIT COUPLE 1/2"DR X 5/16"BIT
- HEX KEY WRENCH 1.5-2-2.5MM

3 SETS/CTN

G.W.: 20.41 KGS

CUFT : 1.36'

### PT-S4105A-BS

1/4" + 1/2" DR. 105PCS SOCKET SET

1/4" + 1/2" DR. 105件套筒扳手組



- 9-1/4" SOCKET 4-4.5-5-5.5-6-7-8-9-10MM
- 8-1/4" DEEP SOCKET 6-7-8-9-10-11-12-13MM
- 5-1/4" STAR SOCKET E4-E5-E6-E7-E8
- 17-1/2" SOCKET 10-11-12-13-14-15-16-17-18-19-20-21-22-24-27-30-32MM
- 8-1/2" STAR SOCKET E10-E11-E12-E14-E16-E18-E20-E24
- 1/4" BIT COUPLE 1/4"DR X 1/4"BIT
- 1/4" 1/2" RATCHET HANDLE
- 1/4" 1/2" UNIVERSAL JOINT
- 1/4" SLIDING T-BAR
- 1/4" 1/2" EXTENSION BAR 50MM - 100MM - 150MM - 125MM - 250MM
- 1/4" BIT PH:0-1-2-2-3 PZ:0-1-2-2-3 TX:T7-T8-T10-T15-T20-T25-T27-T30-T35-T40
- 3/8" MULTI-SOCKET ADAPTOR 3/8" F X 1/4" M
- 3/8" MULTI-SOCKET ADAPTOR 3/8" F X 1/2" M
- 5/16" (8MM) BIT
- PH:3-4 PZ:3-4 SL:8-10-12 HEX:7-8-10-12-14 TX:40-45-50-55
- 1/2" BIT COUPLE 1/2"DR X 5/16"BIT
- 1/2" SPARK PLUG SOCKET 16MM - 21MM
- HEX KEY WRENCH 1.27-1.5-2-2.5MM
- COMBINATION PLIER 7"
- WATER PUMP PLIER

3 SETS/CTN

G.W.: 20.80 KGS

CUFT : 1.36'

### PT-S4110A-BS

1/4" + 1/2" DR. 110PCS SOCKET SET

1/4" + 1/2" DR. 110件套筒扳手組



- 9-1/4" SOCKET 4-4.5-5-5.5-6-7-8-9-10MM
- 8-1/4" STAR SOCKET E4-E5-E6-E7-E8
- 17-1/2" SOCKET 10-11-12-13-14-15-16-17-18-19-20-21-22-24-27-30-32MM
- 8-1/2" STAR SOCKET E10-E11-E12-E14-E16-E18-E20-E24
- 1/4" BIT COUPLE 1/4"DR X 1/4"BIT
- 1/4" 1/2" RATCHET HANDLE
- 1/4" 1/2" UNIVERSAL JOINT
- 1/4" SLIDING T-BAR
- 1/4" 1/2" EXTENSION BAR 75MM - 150MM - 125MM - 250MM
- 1/4" BIT PH:1-2-3 PZ:1-2-3 SL:4-5-5-6-5-7 TX:T7-T8-T10-T15-T20-T25-T27-T30-T35-T40
- 3/8" MULTI-SOCKET ADAPTOR 3/8" F X 1/4" M
- 5/16" (8MM) BIT
- PH:3-4 PZ:3-4 SL:8-10-12 HEX:7-8-10-12-14 TX:T40-T45-T50-T55
- 1/2" SPARK PLUG SOCKET 21MM
- 1/2" BIT COUPLE 1/2"DR X 5/16"BIT
- COMBINATION WRENCH 7-8-9-10-11-12-13-14-15-17-19MM
- HEX KEY WRENCH 1.27-1.5-2-2.5MM
- HEX KEY WRENCH 2-3-4-5-6-8-10MM

3 SETS/CTN

G.W.: 22.00 KGS

CUFT : 1.36'

### PT-S4111A-BS1

1/4" + 1/2" DR. 111PCS SOCKET SET

1/4" + 1/2" DR. 111件套筒扳手組



- 13-1/4" SOCKET 4-4.5-5-5.5-6-7-8-9-10-11-12-13-14MM
- 8-1/4" DEEP SOCKET 6-7-8-9-10-11-12-13MM
- 5-1/4" STAR SOCKET E4-E5-E6-E7-E8
- 20-1/2" SOCKET 8-9-10-11-12-13-14-15-16-17-18-19-20-21-22-23-24-27-30-32MM
- 5-1/2" DEEP SOCKET 14-15-17-19-22MM
- 8-1/2" STAR SOCKET E10-E11-E12-E14-E16-E18-E20-E24
- 1/4" 1/2" RATCHET HANDLE
- 1/4" 1/2" UNIVERSAL JOINT
- 1/4" SLIDING T-BAR
- 1/4" 1/2" EXTENSION BAR 50MM - 100MM - 125MM - 250MM
- 1/4" MULTI-SPANNER HANDLE 150MM
- 1/4" BIT SOCKET PH:1-2 PZ:1-2 SL:4-5-5-7 HEX:3-4-5-6 TX:T8-T10-T15-T20-T25-T27-T30
- 3/8" MULTI-SOCKET ADAPTOR 3/8" F X 1/2" M
- 5/16" (8M/M) BIT
- PH:3-4 PZ:3-4 SL:8-10-12 HEX:8-10-12-14 TX:T30-T40-T45-T50-T55
- 1/2" SPARK PLUG SOCKET 16MM - 21MM
- 1/2" BIT COUPLE 1/2"DR X 5/16"BIT
- HEX KEY WRENCH 1.27-1.5-2-2.5MM

3 SETS/CTN

G.W.: 22.52 KGS

CUFT : 1.36'

### PT-S4122A-BS1

1/4" + 1/2" DR. 122PCS SOCKET SET

1/4" + 1/2" DR. 122件套筒扳手組



- 13-1/4" SOCKET 4-4.5-5-5.5-6-7-8-9-10-11-12-13-14MM
- 13-1/2" SOCKET 15-16-17-18-19-20-21-22-23-24-27-30-32MM
- 1/4" BIT COUPLE 1/4"DR X 1/4"BIT
- 1/4" 1/2" RATCHET HANDLE
- 1/4" 1/2" UNIVERSAL JOINT
- 1/4" SLIDING T-BAR
- 1/4" 1/2" EXTENSION BAR 75MM - 125MM - 250MM
- 1/4" MULTI-SPANNER HANDLE 150MM
- 1/4" BIT PH:0-1-2-2-3 PZ:0-1-2-2-3 SL:2.5-3-4-4.5-5-5.5-6-6.5-7-8 HEX:1.5-2-2.5-3-4-5-5.5-6-7-8 TX:T7-T8-T10-T15-T20-T25-T27-T30-T35-T40
- 3/8" MULTI-SOCKET ADAPTOR 3/8" F X 1/2" M
- 5/16" (8MM) BIT PH:3-4 PZ:3-4 SL:8-10-12 HEX:7-8-10-12-14 TX:T40-T45-T50-T55
- 1/2" SPARK PLUG SOCKET 21MM
- 1/2" BIT COUPLE 1/2"DR X 5/16"BIT
- COMBINATION WRENCH 7-8-9-10-11-12-13-14-15-17-19MM
- HEX KEY WRENCH 2-3-4-5-6-8-10MM
- SHORT STAR L-WRENCH T10-T15-T20-T25-T27-T30-T40-T45-T50

3 SETS/CTN

G.W.: 20.43 KGS

CUFT : 1.36'

### PT-S4124A-BS1

1/4" + 1/2" DR. 124PCS SOCKET SET

1/4" + 1/2" DR. 124件套筒扳手組



- 13-1/4" SOCKET 4-4.5-5-5.5-6-7-8-9-10-11-12-13-14MM
- 8-1/4" DEEP SOCKET 6-7-8-9-10-11-12-13MM
- 13-1/2" SOCKET 15-16-17-18-19-20-21-22-23-24-27-30-32MM
- 4-1/2" DEEP SOCKET 14-15-17-19MM
- 1/4" BIT COUPLE 1/4"DR X 1/4"BIT
- 1/4" 1/2" RATCHET HANDLE
- 1/4" 1/2" UNIVERSAL JOINT
- 1/4" SLIDING T-BAR
- 1/4" 1/2" EXTENSION BAR 50MM - 125MM - 250MM
- 1/4" MULTI-SPANNER HANDLE 150MM
- 1/4" BIT PH:0-1-2-2-3 PZ:0-1-2-2-3 SL:2.5-3-4-4.5-5-5.5-6-6.5-7-8 HEX:1.5-2-2.5-3-4-5-5.5-6-7-8 TX:T7-T8-T10-T15-T20-T25-T27-T30-T35-T40
- 3/8" MULTI-SOCKET ADAPTOR 3/8" F X 1/4" M
- 3/8" MULTI-SOCKET ADAPTOR 3/8" F X 1/2" M
- 5/16" (8MM) BIT
- PH:3-4 PZ:3-4 SL:8-10-12 HEX:7-8-10-12-14 TX:T40-T45-T50-T55
- 1/2" SPARK PLUG SOCKET 16MM - 21MM
- 1/2" BIT COUPLE 1/2"DR X 5/16"BIT
- COMBINATION WRENCH 8-10-12-13-15-17MM
- SHORT HEX L-WRENCH 1.5-2-2.5-3-4-5-6-8-10MM

3 SETS/CTN

G.W.: 21.00 KGS

CUFT : 1.36'





**PT-S4146A-BS1**

**1/4" + 3/8" + 1/2" DR. 146PCS SOCKET SET**  
**1/4" + 3/8" + 1/2" DR. 146件套筒扳手組**

- 10-1/4) SOCKET 4-5-6-7-8-9-10-11-12-13MM
- 10-1/4) DEEP SOCKET 4-5-6-7-8-9-10-11-12-13MM
- 5-1/4) STAR SOCKET E4-E5-E6-E7-E8
- 15-3/8) SOCKET 7-8-9-10-11-12-13-14-15-16-17-18-19-21-22MM
- 4-3/8) DEEP SOCKET 10-11-12-13MM
- 4-3/8) STAR SOCKET E10-E11-E12-E14
- 17-1/2) SOCKET 10-11-12-13-14-15-16-17-18-19-20-21-22-24-27-30-32MM
- 4-1/2) STAR SOCKET E16-E18-E20-E24
- 2-1/2) DEEP IMPACT SOCKET 17-19MM
- 1/4) 3/8) 1/2) RATCHET HANDLE
- 1/4) 3/8) 1/2) UNIVERSAL JOINT
- 1/4) SLIDING T-BAR
- 1/4) 3/8) 1/2) EXTENSION BAR (50MM - 100MM) - (75MM - 150MM - 250MM) (50MM - 125MM - 250MM)
- 1/4) MULTI-SPANNER HANDLE 150MM
- 1/4) BIT SOCKET PH:1-2 PZ:1-2 SL:4-5-5-8 HEX:3-4-5-6-8
- 3/8) SPARK PLUG SOCKET 16MM - 21MM
- 3/8) SOCKET ADAPTOR 3/8" F X 1/4" M - 3/8" F X 1/2" M
- 3/8) BIT SOCKET TX:T40-T50 SPLINE:M6-M8-M10
- 1/2) SOCKET ADAPTOR 1/2" F X 3/8" M
- SHORT STAR L-WRENCH T10-T15-T20-T25-T27-T30-T40-T45-T50
- LONG HEX L-WRENCH H1.5-2-2.5-3-4-5-6-8-10MM
- COMBINATION WRENCH 8-9-10-11-12-13-14-15-16-17-18-19-21-22-24-27-30-32MM

2 SETS/CTN  
G.W.: 29.60 KGS  
CUFT : 2.08'



**PT-T4127A-BS1**

**1/4" + 1/2" DR. 127PCS HAND TOOL SET**  
**1/4" + 1/2" DR. 127件套筒扳手工具組**

- 10-1/4) SOCKET 4-5-6-7-8-9-10-11-12-13MM
- 18-1/2) SOCKET 10-11-12-13-14-15-16-17-18-19-20-21-22-23-24-27-30-32MM
- 1/4) BIT COUPLE 1/4" DR X 1/4" BIT
- 1/4) 1/2) RATCHET HANDLE
- 1/4) 1/2) UNIVERSAL JOINT
- 1/4) SLIDING T-BAR
- 1/4) 1/2) EXTENSION BAR (50MM - 100MM) - (75MM - 250MM)
- 1/4) FLEXIBLE EXTENSION BAR 150MM
- 1/4) MULTI-SPANNER HANDLE 150MM
- 1/4) BIT PH:0-1-2-2-3 PZ:0-1-2-2-3 SL:2.5-3-4-4.5-5-5.5-6-6.5-7-8 HEX:1.5-2-2.5-3-4-5-5.5-6-7-8 TX:T7-T8-T10-T15-T20-T25-T27-T30-T35-T40
- 1/2) SPARK PLUG SOCKET 16MM - 21MM
- 1/2) BIT COUPLE 1/2" DR X 10MM BIT
- 1/2) F-HANDLE 375MM
- 1/2) (10MM) BIT PH:3-4 SL:8-10-12 HEX: H8-10-12 TX:T40-T45-T50 SPLINE:M8-M10-M12 30L HEX: H8-10-12 TX:T40-T45-T50 75L
- COMBINATION WRENCH 6-7-8-9-10-11-12-13-14-15-16-17-19-22-24-27MM
- COMBINATION PLIER 7"
- WATER PUMP PLIER
- SCREWDRIVER PH(+):2X38 PH(+):3X200 SL(-):6.5X38 SL(-):8X200
- HAMMER 300G

2 SETS/CTN  
G.W.: 24.52 KGS  
CUFT : 2.08'



**PT-T4147A-BS1**

**1/4" + 3/8" + 1/2" DR. 147PCS HAND TOOL SET**  
**1/4" + 3/8" + 1/2" DR. 147件套筒扳手工具組**

- 9-1/4) SOCKET 4-4.5-5-5.5-6-7-8-9-10MM
- 5-1/4) STAR SOCKET E4-E5-E6-E7-E8
- 16-3/8) SOCKET 6-7-8-9-10-11-12-13-14-15-16-17-18-19-21-22MM
- 19-1/2) SOCKET 8-10-12-13-14-15-16-17-18-19-20-21-22-23-24-25-27-30-32MM
- 5-1/2) STAR SOCKET E10-E12-E14-E16-E20
- 1/4) BIT COUPLE 1/4" DR X 1/4" BIT
- 1/4) 3/8) 1/2) RATCHET HANDLE
- 1/4) 3/8) 1/2) UNIVERSAL JOINT
- 1/4) 3/8) 1/2) EXTENSION BAR (50MM - 100MM - 150MM) - (75MM - 150MM) - (75MM - 250MM)
- 1/4) FLEXIBLE EXTENSION BAR 150MM
- 1/4) MULTI-SPANNER HANDLE 150MM
- 1/4) BIT PH:0-1-2-2-3 PZ:0-1-2-2-3 SL:2.5-3-4-4.5-5-5.5-6-6.5-7-8 HEX:1.5-2-2.5-3-4-5-5.5-6-7-8 TX:T7-T8-T10-T15-T20-T25-T27-T30-T35-T40
- 3/8) SPARK PLUG SOCKET 16MM - 21MM
- 3/8) SOCKET ADAPTOR 3/8" F X 1/4" M
- 3/8) MULTI-SOCKET ADAPTOR 3/8" F X 1/2" M
- 1/2) MULTI-SOCKET ADAPTOR 1/2" F X 3/8" M
- 1/2) F-HANDLE 375MM
- 1/2) L-HANDLE
- SHORT HEX L-WRENCH 1.5-2-2.5-3-4-5-6-8-10MM
- COMBINATION WRENCH 6-7-8-9-10-11-12-13-14-15-16-17-19-22-24-27MM
- COMBINATION PLIER 7"
- DIAGONAL PLIER 6"
- SCREWDRIVER PH(+):2X150 SL(-):6.5X150
- HAMMER 300G

2 SETS/CTN  
G.W.: 30.30 KGS  
CUFT : 2.08'

Socket Wrench Set

**PT-T4162A-BS1**

**1/4" + 3/8" + 1/2" DR. 162PCS HAND TOOL SET**  
**1/4" + 3/8" + 1/2" DR. 162件套筒扳手工具組**

- 9-1/4) SOCKET 4-4.5-5-5.5-6-7-8-9-10MM
- 5-1/4) STAR SOCKET E4-E5-E6-E7-E8
- 16-3/8) SOCKET 6-7-8-9-10-11-12-13-14-15-16-17-18-19-21-22MM
- 19-1/2) SOCKET 8-10-12-13-14-15-16-17-18-19-20-21-22-23-24-25-27-30-32MM
- 5-1/2) STAR SOCKET E10-E12-E14-E16-E20
- 1/4) BIT COUPLE 1/4" DR X 1/4" BIT
- 1/4) 3/8) 1/2) RATCHET HANDLE
- 1/4) 3/8) 1/2) UNIVERSAL JOINT
- 1/4) 3/8) 1/2) EXTENSION BAR (50MM - 100MM - 150MM) - (75MM - 150MM) - (75MM - 250MM)
- 1/4) FLEXIBLE EXTENSION BAR 150MM
- 1/4) MULTI-SPANNER HANDLE 150MM
- 1/4) BIT PH:0-1-2-2-3 PZ:0-1-2-2-3 SL:2.5-3-4-4.5-5-5.5-6-6.5-7-8 HEX:1.5-2-2.5-3-4-5-5.5-6-7-8 TX:T7-T8-T10-T15-T20-T25-T27-T30-T35-T40
- 3/8) SPARK PLUG SOCKET 16MM - 21MM
- 3/8) SOCKET ADAPTOR 3/8" F X 1/4" M
- 3/8) MULTI-SOCKET ADAPTOR 3/8" F X 1/2" M
- 1/2) MULTI-SOCKET ADAPTOR 1/2" F X 3/8" M
- 1/2) F-HANDLE 375MM
- 1/2) L-HANDLE
- SHORT HEX L-WRENCH 1.5-2-2.5-3-4-5-6-8-10MM
- HEX KEY WRENCH 12-14MM
- COMBINATION WRENCH 6-7-8-9-10-11-12-13-14-15-16-17-18-19-21-22-24-27-32MM
- COMBINATION PLIER 7"
- WATER PUMP PLIER
- SCREWDRIVER PH(+):2X38 PH(+):2X150 PH(+):3X200 SL(-):6.5X38 SL(-):6.5X150 SL(-):8X200
- HAMMER 300G
- CENTER PUNCH NO.2 X 120MM
- TAPER PUNCH 3MM X 120MM
- CAPE CHISEL 5MM X 130MM
- COLD CHISEL 12 X 130MM, 18 X 165MM
- PIN PUNCH 4MM X 150MM

2 SETS/CTN  
G.W.: 32.36 KGS  
CUFT : 2.08'



**PT-B1011AM-B**  
11PCS SPLINE BIT SET  
11件十二角起子頭組

- 1- (1/2") BIT COUPLE 1/2"DR X 10MM
- (10MM) BIT 30L&75L
- 5- SPLINE:M5-M6-M8-M10-M12,30L
- 5- SPLINE:M5-M6-M8-M10-M12,75L

25 SETS/CTN  
G.W.: 13.10 KGS  
CUFT : 1.13'



**PT-B1015AH-B**  
15PCS HEX BIT SET  
15件六角起子頭組

- 1- (1/2") BIT COUPLE 1/2"DR X 10MM
- (10MM) BIT 30L&75L
- 7- HEX:H4-H5-H6-H7-H8-H10-H12,30L
- 7- HEX:H4-H5-H6-H7-H8-H10-H12,75L

25 SETS/CTN  
G.W.: 16.80 KGS  
CUFT : 1.13'



**PT-B1015AT-B**  
15PCS STAR BIT SET  
15件星形起子頭組

- 1- (1/2") BIT COUPLE 1/2"DR X 10MM
- (10MM) BIT 30L&75L
- 7- STAR BIT TX:T20-T25-T30-T40-T45-T50-T55,30L
- 7- STAR BIT TX:T20-T25-T30-T40-T45-T50-T55,75L

25 SETS/CTN  
G.W.: 16.22 KGS  
CUFT : 1.13'



**PT-B1055A-B**  
55PCS BIT SET  
55件起子頭組

- 1- (3/8") BIT COUPLE 3/8"DR X 10MM
- 1- (1/2") BIT COUPLE 1/2"DR X 10MM
- (10MM) BIT 30L&75L
- 2- PH BIT:PH3-PH4,30L
- 3- SL BIT:SL8-SL10-SL12,30L
- 8- MR BIT:MR5-MR6-MR7-MR8-MR9-MR10-MR12-MR14,30L
- 2- MR BIT:MR12-MR14,75L
- 6- HEX BIT:H5-H6-H7-H8-H10-H12MM,30L
- 6- HEX BIT:H5-H6-H7-H8-H10-H12MM,75L
- 8- STAR BIT:T20-T25-T30-T40-T45-T50-T55-T60,30L
- 8- STAR BIT:T20-T25-T30-T40-T45-T50-T55-T60,75L
- 5- SPLINE:M5-M6-M8-M10-M12,30L
- 5- SPLINE:M5-M6-M8-M10-M12,75L

12 SETS/CTN  
G.W.: 24.40 KGS  
CUFT : 1.11'



**PT-S409E-BS1**  
1/2" DR. 9PCS E SOCKET SET  
1/2" DR. 9件星形套筒扳手組

- (1/2") 9- E SOCKET E10-E11-E12-E14-E16-E18-E20-E21-E22

30 SETS/CTN  
G.W.: 22.90 KGS  
CUFT : 1.01'



**PT-S414E-BS1**  
1/4" +3/8" +1/2" DR. 14PCS E SOCKET SET  
1/4" +3/8" +1/2" DR. 14件星形套筒扳手組

- 5- (1/4") E SOCKET E4-E5-E6-E7-E8
- 5- (3/8") E SOCKET E10-E11-E12-E14-E16
- 4- (1/2") E SOCKET E18-E20-E21-E22-E24

30 SETS/CTN  
G.W.: 20.61 KGS  
CUFT : 1.01'



VICTORY  
Design handle

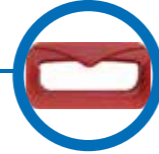

PANEL DESIGN



LOGO  
Position



METALLIC PIN HINGE

The pin can extend the service life of the box.



**PT-S221B-BS1**

1/4" DR. 21PCS SOCKET SET  
1/4" DR. 21件套筒扳手組

- 1/4" 11 - SOCKET 4-4.5-5-6-7-8-9-10-11-12-13 MM
- 1 - RATCHET HANDLE
- 1 - UNIVERSAL JOINT
- 1 - EXTENSION BAR 50MM
- 6 - BIT SOCKET PH:1-2-3 SL:4-5-5-7
- 1 - MULTI-SPANNER HANDLE 150MM

20 SETS/CTN  
G.W.: 15.60 KGS  
CUFT : 1.27'



**PT-S229C-BS1**

1/4" DR. 29PCS SOCKET SET  
1/4" DR. 29件套筒扳手組

- 1/4" 12 - SOCKET 4-4.5-5-5.5-6-7-8-9-10-11-12-13 MM
- 1 - RATCHET HANDLE
- 1 - UNIVERSAL JOINT
- 1 - SLIDING T-BAR
- 1 - EXTENSION BAR 50MM
- 1 - FLEXIBLE EXTENSION BAR 150MM
- 1 - MULTI-SPANNER HANDLE 150MM
- 11 - BIT SOCKET PH:1-2-3 SL:4-4.5-7 HEX:3-4-5-6-7

20 SETS/CTN  
G.W.: 18.00 KGS  
CUFT : 1.27'



**PT-S453A-BS1**

1/2" DR. 53PCS SOCKET SET  
1/2" DR. 53件套筒扳手組

- 15-1/2" SOCKET 10-11-12-13-14-15-16-17-19-21-22-24-27-30-32MM
- 4-1/2" DEEP SOCKET 10-13-17-19MM
- 5/16 (8MM) BIT PH:3-4 PZ:3-4 SL:8-10-12 HEX:8-10-12 TX:T40-T45-T50-T55-T60 SPLINE:M5-M6-M8-M10-M12
- 1/2" BIT COUPLE 1/2"DR X 5/16"BIT
- 1/2" RATCHET HANDLE
- 1/2" UNIVERSAL JOINT
- 1/2" EXTENSION BAR 125MM
- COMBINATION WRENCH 10-12-13-14-17-19MM
- SCREWDRIVER PH(+):1X75 PH(+):2X100 SL(-):5.5X75 SL(-):6.5X100

5 SETS/CTN  
G.W.: 24.55 KGS  
CUFT : 1.49'



**PT-S495B-BS1**

1/4" + 1/2" DR. 95PCS SOCKET SET  
1/4" + 1/2" DR. 95件套筒扳手組

- 9-1/4" SOCKET 4-5-6-7-8-9-10-11-12MM
- 13-1/2" SOCKET 10-11-12-13-14-15-17-19-22-24-27-30-32MM
- 1/4" BIT COUPLE 1/4"DR X 1/4"BIT
- 1/4" 1/2" RATCHET HANDLE
- 1/4" 1/2" UNIVERSAL JOINT
- 1/4" SLIDING T-BAR
- 1/4" 1/2" EXTENSION BAR 75MM - 125MM - 250MM
- 1/4" BIT PH:0-1-2-2-3 PZ:0-1-2-2-3 SL:2.5-3-4-4.5-5-5.5-6-6.5-7-8 HEX:1.5-2-2.5-3-4-5-5.5-6-7-8 TX:T7-T8-T10-T15-T20-T25-T30-T35-T40
- 3/8" MULTI-SOCKET ADAPTOR 3/8" F X 1/2" M
- 1/2" SPARK PLUG SOCKET 21MM
- COMBINATION WRENCH 7-8-9-10-11-12-13-14-15-17-19MM
- DOUBLE FLEXIBLE SOCKET WRENCH 8X9 - 10X11 - 12X13 - 14X15MM
- HEX KEY WRENCH 2-3-4-5-6-8-10MM

3 SETS/CTN  
G.W.: 19.60 KGS  
CUFT : 1.15'



**PT-S498C-BS1**

1/4" + 1/2" DR. 98PCS SOCKET SET  
1/4" + 1/2" DR. 98件套筒扳手組

- 9-1/4" SOCKET 4-5-6-7-8-9-10-11-12MM
- 3-1/4" DEEP SOCKET 8-10-13MM
- 16-1/2" SOCKET 10-11-12-13-14-15-16-17-18-19-21-22-24-27-30-32MM
- 4-1/2" DEEP SOCKET 14-15-17-19MM
- 1/4" 1/2" RATCHET HANDLE
- 1/4" 1/2" UNIVERSAL JOINT
- 1/4" SLIDING T-BAR
- 1/4" 1/2" EXTENSION BAR 50MM - 100MM - 125MM - 250MM
- 1/4" BIT SOCKET 37L PH:1-2 PZ:1-2 HEX:3-4-5-6-8 SL:4-5.5-6.5 TX:T10-T15-T20-T25-T30-T40
- 3/8" MULTI-SOCKET ADAPTOR 3/8" F X 1/2" M
- 5/16 (8MM) BIT 30L PH:3-4 PZ:3-4 SL:8-10-12 HEX:8-10-12 TX:T40-T45-T50-T55-T60 SPLINE:M5-M6-M8-M10-M12
- 1/2" SPARK PLUG SOCKET 16MM - 21MM
- 1/2" BIT COUPLE 1/2"DR X 5/16"BIT
- COMBINATION WRENCH 10-12-13-14-17MM
- SHORT HEX L-WRENCH 1.5-2-2.5-3-4-5-6-8-10MM
- COMBINATION PLIER 7"

3 SETS/CTN  
G.W.: 21.24 KGS  
CUFT : 1.15'



**PT-S4100B-BS1**

1/4" + 1/2" DR. 100PCS SOCKET SET  
1/4" + 1/2" DR. 100件套筒扳手機組

- 9-104 SOCKET 4-4.5-5-5.5-6-7-8-9-10MM
- 5-104 STAR SOCKET E4-E5-E6-E7-E8
- 17-102 SOCKET 10-11-12-13-14-15-16-17-18-19-20-21-22-24-27-30-32MM
- 8-102 STAR SOCKET E10-E11-E12-E14-E16-E18-E20-E24
- 104 BIT COUPLE 1/4"DR X 1/4" BIT
- 104 102 RATCHET HANDLE
- 104 102 UNIVERSAL JOINT
- 104 102 EXTENSION BAR 150MM - 125MM - 250MM
- 104 BIT PH:0-1-2-2-3 PZ:0-1-2-2-3 TX:T7-T8-T10-T15-T20-T25-T27-T30-T35-T40
- 38 MULTI-SOCKET ADAPTOR 3/8" F X 1/2" M
- 516 (8MM) BIT
- PH:3-4 PZ:3-4 SL:8-10-12 HEX:7-8-10-12-14 TX:T40-T45-T50-T55
- 102 BIT COUPLE 1/2"DR X 5/16" BIT
- COMBINATION WRENCH 8-9-10-11-12-13-14-15-17-19-22MM
- HEX KEY WRENCH 1.27-1.5-2-2.5MM

3 SETS/CTN  
G.W.: 19.78 KGS  
CUFT : 1.15'



**PT-T422A-BS1**

1/2" DR. 22PCS HAND TOOL SET  
1/2" DR. 22件套筒扳手工具組

- 102 12-SOCKET 10-12-13-14-15-16-17-19-21-22-24-27MM
- 1-RATCHET HANDLE
- 1-UNIVERSAL JOINT
- 1-EXTENSION BAR 125MM
- 1-COMBINATION PLIER 7"
- 1-WATER PUMP PLIER
- 4-SCREWDRIVER PH(+):1X75 PH(+):2X100 SL(-):5.5X75 SL(-):6.5X100
- 1-ADJUSTABLE WRENCH 8"

6 SETS/CTN  
G.W.: 22.60 KGS  
CUFT : 1.51'



**PT-T428A-BS1**

1/2" DR. 28PCS HAND TOOL SET  
1/2" DR. 28件套筒扳手工具組

- 17-102 SOCKET 8-9-10-11-12-13-14-15-16-17-18-19-20-21-22-24-27MM
- 38 MULTI-SOCKET ADAPTOR 3/8" F X 1/2" M
- 102 RATCHET HANDLE
- 102 UNIVERSAL JOINT
- 102 EXTENSION BAR 75MM - 250MM
- COMBINATION PLIER 7"
- SCREWDRIVER PH(+):1X75 PH(+):2X100 SL(-):5.5X75 SL(-):6.5X100
- ADJUSTABLE WRENCH 8"

6 SETS/CTN  
G.W.: 24.94 KGS  
CUFT : 1.51'



**PT-T454A-BS1**

1/2" DR. 54PCS HAND TOOL SET  
1/2" DR. 54件套筒扳手工具組

- 15-102 SOCKET 10-11-12-13-14-15-16-17-19-21-22-24-27-30-32MM
- 4-102 DEEP SOCKET 10-13-17-19MM
- 516 (8MM) BIT PH:3-4 PZ:3-4 SL:8-10-12 HEX:8-10-12 TX:T40-T45-T50-T55-T60 SPLINE:M5-M6-M8-M10-M12
- 102 BIT COUPLE 1/2"DR X 5/16"BIT
- 102 RATCHET HANDLE
- 102 UNIVERSAL JOINT
- 102 EXTENSION BAR 125MM
- HEX KEY WRENCH 3-4-5-6-8-10MM
- SCREWDRIVER PH(+):1X75 PH(+):2X100 SL(-):5.5X75 SL(-):6.5X100
- ADJUSTABLE WRENCH 8"

5 SETS/CTN  
G.W.: 24.45 KGS  
CUFT : 1.49'



**PT-T458A-BS1**

1/2" DR. 58PCS HAND TOOL SET  
1/2" DR. 58件套筒扳手工具組

- 11-104 SOCKET 4-5-6-7-8-9-10-11-12-13-14MM
- 8-102 SOCKET 15-17-19-22-24-27-30-32MM
- 104 BIT COUPLE 1/4"DR X 1/4" BIT
- 104 102 UNIVERSAL JOINT
- 104 SLIDING T-BAR
- 104 102 EXTENSION BAR 100MM - 250MM
- 104 MULTI-SPANNER HANDLE 150MM
- 104 BIT PH:0-1-2-3 PZ:1-2-3 SL:3-4-5-5-7 HEX:2-3-4-5-6-7 TX:T10-T15-T20-T25-T30
- 38 MULTI-SOCKET ADAPTOR 3/8" F X 1/2" M
- 102 SPARK PLUG SOCKET 16MM - 21MM
- 102 RATCHET HANDLE

- COMBINATION PLIER 7"
- WATER PUMP PLIER
- SCREWDRIVER PH(+):2X100 SL(-):6.5X100
- ADJUSTABLE WRENCH 8"
- HAMMER 300G

4 SETS/CTN  
G.W.: 21.87 KGS  
CUFT : 1.52'



**PT-T469A-BS1**

1/2" DR. 69PCS HAND TOOL SET  
1/2" DR. 69件套筒扳手工具組

- 8-104 SOCKET 6-7-8-9-10-11-12-13MM
- 11-102 SOCKET 10-11-12-13-14-15-17-19-22-24-27MM
- 104 BIT COUPLE 1/4"DR X 1/4"BIT
- 104 SLIDING T-BAR
- 104 MULTI-SPANNER HANDLE 150MM
- 104 BIT PH:0-1-2-3 PZ:1-2-3 SL:3-4-5-5-7 HEX:2-3-4-5-6-7 TX:T10-T15-T20-T25-T30
- 102 SPARK PLUG SOCKET 16MM - 21MM
- 102 RATCHET HANDLE
- 102 UNIVERSAL JOINT
- 102 EXTENSION BAR 125MM
- COMBINATION WRENCH 10-12-13-14-15-17MM

- HEX KEY WRENCH 2-3-4-5-6-8MM
- COMBINATION PLIER 7"
- WATER PUMP PLIER
- SCREWDRIVER PH(+):2X38 PH(+):2X100 SL(-):6.5X100 SL(-):8X200 SL(-):6.5X38
- HAMMER 300G

4 SETS/CTN  
G.W.: 23.00 KGS  
CUFT : 1.52'



**PT-T474B-BS1**

1/4" + 1/2" DR. 74PCS HAND TOOL SET  
1/4" + 1/2" DR. 74件套筒扳手工具組

- 9-104 SOCKET 4-5-6-7-8-9-10-11-12MM
- 4-104 DEEP SOCKET 8-10-12-13MM
- 13-102 SOCKET 10-11-12-13-14-15-17-19-22-24-27-30-32MM
- 5-102 DEEP SOCKET 14-15-17-19-22MM
- 104 BIT COUPLE 1/4"DR X 1/4" BIT
- 104 102 RATCHET HANDLE
- 104 102 UNIVERSAL JOINT
- 104 SLIDING T-BAR
- 104 102 EXTENSION BAR 100MM - 125MM
- 104 MULTI-SPANNER HANDLE 150MM
- 104 BIT PH:0-1-2-3 PZ:1-2-3 SL:3-4-5-5-7 HEX:2-3-4-5-6-7 TX:T10-T15-T20-T25-T30
- COMBINATION WRENCH 10-12-13-14-17-19-22MM

- COMBINATION PLIER 7"
- WATER PUMP PLIER
- SCREWDRIVER PH(+):2X100 SL(-):6.5X100
- HAMMER 300G

3 SETS/CTN  
G.W.: 20.55 KGS  
CUFT : 1.18'



**PT-T478B-BS1**

1/4" + 1/2" DR. 78PCS HAND TOOL SET  
1/4" + 1/2" DR. 78件套筒扳手工具組

- 9-104 SOCKET 4-5-6-7-8-9-10-11-12MM
- 4-104 DEEP SOCKET 8-10-12-13MM
- 13-102 SOCKET 10-12-13-14-15-16-17-18-19-21-22-24-27MM
- 104 BIT COUPLE 1/4"DR X 1/4" BIT
- 104 102 RATCHET HANDLE
- 104 102 UNIVERSAL JOINT
- 104 SLIDING T-BAR
- 104 102 EXTENSION BAR 100MM - 250MM
- 104 MULTI-SPANNER HANDLE 150MM
- 104 BIT PH:0-1-2-3 PZ:1-2-3 SL:3-4-5-5-7 HEX:2-3-4-5-6-7 TX:T10-T15-T20-T25-T30
- 38 MULTI-SOCKET ADAPTOR 3/8" F X 1/2" M
- COMBINATION WRENCH 10-12-13-14-17MM
- SHORT HEX L-WRENCH 1.5-2-2.5-3-4-5-6-8-10MM

- COMBINATION PLIER 7"
- WATER PUMP PLIER
- SCREWDRIVER PH(+):2X100 SL(-):6.5X100
- ADJUSTABLE WRENCH 8"
- HAMMER 300G

3 SETS/CTN  
G.W.: 18.97 KGS  
CUFT : 1.18'



STAR SOCKET

1/4" DR. STAR SOCKET CR-V  
1/4" 星形套筒 鉻鈦鋼

ITEM NO. (編號)	SIZE (規格)	PCS/BOX (數量/盒)	PCS/CTN (數量/箱)	ITEM NO. (編號)	SIZE (規格)	PCS/BOX (數量/盒)	PCS/CTN (數量/箱)
8007-204	E4	100	2000	8007-208	E8	100	2000
8007-205	E5	100	2000	8007-210	E10	100	2000
8007-206	E6	100	2000	8007-211	E11	100	2000
8007-207	E7	100	2000				

3/8" DR. STAR SOCKET CR-V  
3/8" 星形套筒 鉻鈦鋼

ITEM NO. (編號)	SIZE (規格)	PCS/BOX (數量/盒)	PCS/CTN (數量/箱)	ITEM NO. (編號)	SIZE (規格)	PCS/BOX (數量/盒)	PCS/CTN (數量/箱)
8007-306	E6	50	1000	8007-312	E12	40	800
8007-307	E7	50	1000	8007-314	E14	35	700
8007-308	E8	45	900	8007-316	E16	30	600
8007-310	E10	45	900	8007-318	E18	25	500
8007-311	E11	40	800	8007-320	E20	20	400

1/2" DR. STAR SOCKET CR-V  
1/2" 星形套筒 鉻鈦鋼

ITEM NO. (編號)	SIZE (規格)	PCS/BOX (數量/盒)	PCS/CTN (數量/箱)	ITEM NO. (編號)	SIZE (規格)	PCS/BOX (數量/盒)	PCS/CTN (數量/箱)
8007-408	E8	20	400	8007-416	E16	20	400
8007-410	E10	20	400	8007-418	E18	20	400
8007-411	E11	20	400	8007-420	E20	10	200
8007-412	E12	20	400	8007-422	E22	10	200
8007-414	E14	20	400	8007-424	E24	10	200

1/4" DR. SOCKET 6PT CR-V  
1/4" 短套筒 六角 鉻鈦鋼

ITEM NO. (編號)	SIZE (規格)	PCS/BOX (數量/盒)	PCS/CTN (數量/箱)	ITEM NO. (編號)	SIZE (規格)	PCS/BOX (數量/盒)	PCS/CTN (數量/箱)
8001-204	4mm	100	2000	8001-209	9mm	70	1400
8001-245	4.5mm	100	2000	8001-210	10mm	70	1400
8001-205	5mm	100	2000	8001-211	11mm	50	1000
8001-255	5.5mm	100	2000	8001-212	12mm	50	1000
8001-206	6mm	100	2000	8001-213	13mm	40	1000
8001-207	7mm	100	2000	8001-214	14mm	35	700
8001-208	8mm	100	2000				

1/2" DR. SOCKET 6PT CR-V  
1/2" 短套筒 六角 鉻鈦鋼

ITEM NO. (編號)	SIZE (規格)	PCS/BOX (數量/盒)	PCS/CTN (數量/箱)	ITEM NO. (編號)	SIZE (規格)	PCS/BOX (數量/盒)	PCS/CTN (數量/箱)
8001-408	8mm	20	400	8001-420	20mm	10	200
8001-409	9mm	20	400	8001-421	21mm	10	200
8001-410	10mm	20	400	8001-422	22mm	10	200
8001-411	11mm	20	400	8001-423	23mm	10	200
8001-412	12mm	20	400	8001-424	24mm	10	200
8001-413	13mm	20	400	8001-425	25mm	10	100
8001-414	14mm	20	400	8001-426	26mm	10	100
8001-415	15mm	20	400	8001-427	27mm	10	100
8001-416	16mm	20	400	8001-428	28mm	10	100
8001-417	17mm	10	300	8001-429	29mm	10	100
8001-418	18mm	10	300	8001-430	30mm	10	100
8001-419	19mm	10	300	8001-432	32mm	10	100

3/8" DR. SOCKET 6PT CR-V  
3/8" 短套筒 六角 鉻鈦鋼

ITEM NO. (編號)	SIZE (規格)	PCS/BOX (數量/盒)	PCS/CTN (數量/箱)	ITEM NO. (編號)	SIZE (規格)	PCS/BOX (數量/盒)	PCS/CTN (數量/箱)
8001-306	6mm	40	800	8001-316	16mm	20	400
8001-307	7mm	40	800	8001-317	17mm	20	400
8001-308	8mm	40	800	8001-318	18mm	30	360
8001-309	9mm	40	800	8001-319	19mm	30	360
8001-310	10mm	40	800	8001-320	20mm	20	300
8001-311	11mm	40	800	8001-321	21mm	20	300
8001-312	12mm	40	800	8001-322	22mm	20	300
8001-313	13mm	30	600	8001-323	23mm	15	225
8001-314	14mm	30	600	8001-324	24mm	15	225
8001-315	15mm	20	400				

DEEP SOCKET

1/4" DR. DEEP SOCKET 6PT CR-V  
1/4" 長套筒 六角 鉻鈦鋼

ITEM NO. (編號)	SIZE (規格)	PCS/BOX (數量/盒)	PCS/CTN (數量/箱)	ITEM NO. (編號)	SIZE (規格)	PCS/BOX (數量/盒)	PCS/CTN (數量/箱)
8002-204	4mm	50	1000	8002-209	9mm	40	800
8002-245	4.5mm	50	1000	8002-210	10mm	35	700
8002-205	5mm	50	1000	8002-211	11mm	25	500
8002-255	5.5mm	50	1000	8002-212	12mm	25	500
8002-206	6mm	50	1000	8002-213	13mm	20	400
8002-207	7mm	50	1000	8002-214	14mm	20	300
8002-208	8mm	40	800				

1/2" DR. DEEP SOCKET 6PT CR-V  
1/2" 長套筒 六角 鉻鈦鋼

ITEM NO. (編號)	SIZE (規格)	PCS/BOX (數量/盒)	PCS/CTN (數量/箱)	ITEM NO. (編號)	SIZE (規格)	PCS/BOX (數量/盒)	PCS/CTN (數量/箱)
8002-408	8mm	15	180	8002-420	20mm	10	120
8002-409	9mm	15	180	8002-421	21mm	10	120
8002-410	10mm	15	180	8002-422	22mm	10	120
8002-411	11mm	15	180	8002-423	23mm	10	100
8002-412	12mm	15	180	8002-424	24mm	10	100
8002-413	13mm	15	180	8002-425	25mm	10	60
8002-414	14mm	15	180	8002-426	26mm	10	60
8002-415	15mm	15	180	8002-427	27mm	10	60
8002-416	16mm	15	180	8002-428	28mm	10	60
8002-417	17mm	15	180	8002-429	29mm	10	60
8002-418	18mm	10	120	8002-430	30mm	10	60
8002-419	19mm	10	120	8002-432	32mm	10	60

3/8" DR. DEEP SOCKET 6PT CR-V  
3/8" 長套筒 六角 鉻鈦鋼

ITEM NO. (編號)	SIZE (規格)	PCS/BOX (數量/盒)	PCS/CTN (數量/箱)	ITEM NO. (編號)	SIZE (規格)	PCS/BOX (數量/盒)	PCS/CTN (數量/箱)
8002-306	6mm	20	400	8002-316	16mm	20	240
8002-307	7mm	20	400	8002-317	17mm	15	180
8002-308	8mm	20	400	8002-318	18mm	15	180
8002-309	9mm	20	400	8002-319	19mm	15	180
8002-310	10mm	20	400	8002-320	20mm	8	160
8002-311	11mm	20	400	8002-321	21mm	8	120
8002-312	12mm	30	360	8002-322	22mm	7	105
8002-313	13mm	25	300	8002-323	23mm	5	60
8002-314	14mm	25	300	8002-324	24mm	5	60
8002-315	15mm	20	240				

SPARK PLUG SOCKET

RUBBER(膠套)

3/8" DR. SPARK PLUG SOCKET CR-V  
3/8" 火星套筒 6PT 鉻鈦鋼

ITEM NO. (編號)	SIZE (規格)	PCS/BOX (數量/盒)	PCS/CTN (數量/箱)	ITEM NO. (編號)	SIZE (規格)	PCS/BOX (數量/盒)	PCS/CTN (數量/箱)
8013-316R	16mm	20	240	8013-321R	21mm	15	150

1/2" DR. SPARK PLUG SOCKET CR-V  
1/2" 火星套筒 6PT 鉻鈦鋼

ITEM NO. (編號)	SIZE (規格)	PCS/BOX (數量/盒)	PCS/CTN (數量/箱)	ITEM NO. (編號)	SIZE (規格)	PCS/BOX (數量/盒)	PCS/CTN (數量/箱)
8013-416R	16mm	20	240	8013-421R	21mm	15	150

MAGNETIC(磁性)

3/8" DR. SPARK PLUG SOCKET CR-V  
3/8" 火星套筒 6PT 鉻鈦鋼

ITEM NO. (編號)	SIZE (規格)	PCS/BOX (數量/盒)	PCS/CTN (數量/箱)	ITEM NO. (編號)	SIZE (規格)	PCS/BOX (數量/盒)	PCS/CTN (數量/箱)
8013-316M	16mm	20	240	8013-321M	21mm	15	150

1/2" DR. SPARK PLUG SOCKET CR-V  
1/2" 火星套筒 6PT 鉻鈦鋼

ITEM NO. (編號)	SIZE (規格)	PCS/BOX (數量/盒)	PCS/CTN (數量/箱)	ITEM NO. (編號)	SIZE (規格)	PCS/BOX (數量/盒)	PCS/CTN (數量/箱)
8013-416M	16mm	20	240	8013-421M	21mm	15	150



PERFECT TOOLS®

RATCHET HANDLE 棘輪柄

SINCE 2005



Tools best partner

72T

GEARS (HEAVY DUTY)

STRAIGHT RATCHET HANDLE

棘輪柄



ITEM NO. (編號)	SIZE (規格)	PCS/BOX (數量/盒)	PCS/CTN (數量/箱)	CUFT (材積)
7202-272	1/4"DR.	5	150	0.69'
7202-372	3/8"DR.	10	80	0.85'
7202-472	1/2"DR.	4	40	0.87'

72T

GEARS (HEAVY DUTY)

CURVED RATCHET HANDLE

彎型棘輪柄



ITEM NO. (編號)	SIZE (規格)	PCS/BOX (數量/盒)	PCS/CTN (數量/箱)	CUFT (材積)
7203-272	1/4"DR.	20	160	0.78'
7203-372	3/8"DR.	8	64	0.57'
7203-472	1/2"DR.	4	40	0.87'

72T

GEARS (HEAVY DUTY)

STRAIGHT RATCHET HANDLE

棘輪柄(全拋)



ITEM NO. (編號)	SIZE (規格)	PCS/BOX (數量/盒)	PCS/CTN (數量/箱)	CUFT (材積)
7200-272	1/4"DR.	5	100	0.48'
7200-372	3/8"DR.	6	60	0.41'
7200-472	1/2"DR.	5	40	0.7'



43T

GEARS

RATCHET HANDLE

棘輪柄

ITEM NO. (編號)	SIZE (規格)	PCS/BOX (數量/盒)	PCS/CTN (數量/箱)	CUFT (材積)
7204-643	3/4"DR.	2	8	0.58'

WITH QUICK RELEASED / SPEEDING DISC 有快落功能



24T

GEARS

RATCHET HANDLE

棘輪柄

ITEM NO. (編號)	SIZE (規格)	PCS/BOX (數量/盒)	PCS/CTN (數量/箱)	CUFT (材積)
7206-624	3/4"DR.	2	8	0.58'

NON QUICK RELEASED / 無快落功能



24T

GEARS

RATCHET HANDLE

棘輪柄

ITEM NO. (編號)	SIZE (規格)	PCS/BOX (數量/盒)	PCS/CTN (數量/箱)	CUFT (材積)
7205-624	3/4"DR.	2	8	0.58'

WITH QUICK RELEASED / 有快落功能



24T

GEARS

RATCHET HANDLE

棘輪柄

ITEM NO. (編號)	SIZE (規格)	PCS/BOX (數量/盒)	PCS/CTN (數量/箱)	CUFT (材積)
7206-124	1"DR.	1	4	0.66'



**UNIVERSAL JOINT CR-V**

**萬向接頭 鉻釩鋼**

ITEM NO.(編號)	SIZE(規格)	PCS/BOX(數量/盒)	PCS/CTN(數量/箱)	CUFT(材積)
7010-21	1/4"DR.	50	1000	0.48'
7010-31	3/8"DR.	15	300	0.48'
7010-41	1/2"DR.	15	150	0.41'
7010-61	3/4"DR.	4	40	0.41'
7010-11	1"DR.	2	20	0.41'

**EXTENSION BAR CR-V**

**接桿 鉻釩鋼**



ITEM NO.(編號)	SIZE(規格)	L/mm(長度)	PCS/BOX(數量/盒)	PCS/CTN(數量/箱)	CUFT(材積)
7001-202	1/4"DR.	50	60	900	0.36'
7001-203	1/4"DR.	75	40	600	0.36'
7001-204	1/4"DR.	100	30	450	0.36'
7001-206	1/4"DR.	150	20	300	0.36'
7001-303	3/8"DR.	75	20	300	0.36'
7001-306	3/8"DR.	150	10	150	0.36'
7001-310	3/8"DR.	250	10	100	0.4'
7001-403	1/2"DR.	75	12	180	0.36'
7001-405	1/2"DR.	125	10	100	0.4'
7001-406	1/2"DR.	150	6	90	0.36'
7001-410	1/2"DR.	250	5	50	0.4'
7001-604	3/4"DR.	100	6	60	0.44'
7001-608	3/4"DR.	200	3	30	0.44'
7001-616	3/4"DR.	400	4	16	0.47'
7001-106	1"DR.	150	4	16	0.47'
7001-108	1"DR.	200	4	16	0.47'
7001-116	1"DR.	400	2	8	0.47'

**WOBBLY & FIXED EXTENSION BAR CR-V**

**雙用接桿(球頭+固定) 鉻釩鋼**



ITEM NO.(編號)	SIZE(規格)	L/mm(長度)	PCS/BOX(數量/盒)	PCS/CTN(數量/箱)	CUFT(材積)
7002-202	1/4"DR.	50	60	900	0.36'
7002-203	1/4"DR.	75	40	600	0.36'
7002-204	1/4"DR.	100	30	450	0.36'
7002-206	1/4"DR.	150	20	300	0.36'
7002-303	3/8"DR.	75	20	300	0.36'
7002-306	3/8"DR.	150	10	150	0.36'
7002-310	3/8"DR.	250	10	100	0.4'
7002-403	1/2"DR.	75	12	180	0.36'
7002-405	1/2"DR.	125	10	100	0.4'
7002-406	1/2"DR.	150	6	90	0.36'
7002-410	1/2"DR.	250	5	50	0.4'

**FLEXIBLE EXTENSION BAR CR-V**

**彈性接桿 鉻釩鋼**



ITEM NO.(編號)	SIZE(規格)	L/mm(長度)	PCS/BOX(數量/盒)	PCS/CTN(數量/箱)	CUFT(材積)
7004-206	1/4"DR.	150	20	400	0.48'



**SPANNER HANDLE CR-V**

**方桿 鉻釩鋼**

ITEM NO.(編號)	SIZE(規格)	L/mm(長度)	PCS/BOX(數量/盒)	PCS/CTN(數量/箱)	CUFT(材積)
7015-2060	1/4"DR.	150	10	200	0.83'



**MULTI-SPANNER HANDLE CR-V**

**雙頭方桿 鉻釩鋼**

ITEM NO.(編號)	SIZE(規格)	L/mm(長度)	PCS/BOX(數量/盒)	PCS/CTN(數量/箱)	CUFT(材積)
7015-2061	1/4"DR.	150	10	200	0.83'



ITEM NO.(編號)	SIZE(規格)	L/mm(長度)	PCS/BOX(數量/盒)	PCS/CTN(數量/箱)	CUFT(材積)
7015-2062	1/4"DR.	150	10	200	0.83'



**SLIDING T-BAR CR-V**

**滑桿 鉻釩鋼**

ITEM NO.(編號)	SIZE(規格)	L/mm(長度)	PCS/BOX(數量/盒)	PCS/CTN(數量/箱)	CUFT(材積)
7013-245	1/4"DR.	112	20	500	0.58'
7013-308	3/8"DR.	200	10	120	0.51'
7013-410	1/2"DR.	250	10	50	0.44'
7013-412	1/2"DR.	300	10	50	0.5'
7013-618	3/4"DR.	450	3	12	0.47'
7013-620	3/4"DR.	500	3	12	0.47'
7013-122	1"DR.	550	2	8	0.72'

**F-HANDLE CR-V**

**F桿(倍力桿) 鉻釩鋼**



ITEM NO.(編號)	SIZE(規格)	L/mm(長度)	PCS/BOX(數量/盒)	PCS/CTN(數量/箱)	CUFT(材積)
7017-206	1/4"DR.	150	10	200	0.48'
7017-308	3/8"DR.	200	8	80	0.41'
7017-310	3/8"DR.	250	7	70	0.4'
7017-415	1/2"DR.	375	5	30	0.69'
7017-418	1/2"DR.	450	6	24	0.47'
7017-619	3/4"DR.	450	4	12	0.38'
7017-126	1"DR.	650	2	8	0.72'



**L-HANDLE CR-V**

**L桿 鉻釩鋼**

ITEM NO. (編號)	SIZE (規格)	L/mm (長度)	PCS/BOX (數量/盒)	PCS/CTN (數量/箱)	CUFT (材積)
7022-410	1/2"DR.	250	20	60	0.33'
7022-412	1/2"DR.	300	10	50	0.5'

**L-HANDLE CR-V**

**L桿 鉻釩鋼**

ITEM NO. (編號)	SIZE (規格)	L/mm (長度)	PCS/BOX (數量/盒)	PCS/CTN (數量/箱)	CUFT (材積)
7023-612	3/4"DR.	300	2	16	0.7'
7023-618	3/4"DR.	450	2	12	0.76'

**MULTI-SOCKET ADAPTOR CR-V**

**三用接頭 鉻釩鋼**

ITEM NO. (編號)	SIZE (規格)	PCS/BOX (數量/盒)	PCS/CTN (數量/箱)	CUFT (材積)
7021-01	3/8" F X 1/4" M	40	600	0.36'
7021-02	3/8" F X 1/2" M	30	300	0.47'
7021-04	1/2" F X 3/8" M	30	300	0.47'

**SOCKET ADAPTOR CR-V**

**互換接頭 鉻釩鋼**

ITEM NO. (編號)	SIZE (規格)	PCS/BOX (數量/盒)	PCS/CTN (數量/箱)	CUFT (材積)
7019-01	1/4" F X 3/8" M	100	1000	0.24'
7019-02	3/8" F X 1/4" M	55	825	0.36'
7019-03	3/8" F X 1/2" M	30	450	0.36'
7019-04	1/2" F X 3/8" M	35	350	0.41'
7019-05	1/2" F X 3/4" M	24	144	0.29'
7019-06	3/4" F X 1/2" M	10	100	0.41'
7019-07	3/4" F X 1" M	4	80	0.48'
7019-08	1" F X 3/4" M	5	50	0.41'

**EXTRA LONG HEX L-WRENCH CR-V**

**特長內六角扳手 鉻釩鋼**

ITEM NO. (編號)	SIZE (規格)	PCS/BOX (數量/盒)
7100-315	1.5 mm	300
7100-302	2 mm	240
7100-325	2.5 mm	150
7100-303	3 mm	100
7100-304	4 mm	60
7100-305	5 mm	70
7100-306	6 mm	30
7100-308	8 mm	20
7100-310	10 mm	10
7100-312	12 mm	6
7100-314	14 mm	6
7100-317	17 mm	6
7100-319	19 mm	5



**BALL POINT EXTRA LONG HEX L-WRENCH CR-V**

**球頭 特長內六角扳手 鉻釩鋼**

ITEM NO. (編號)	SIZE (規格)	PCS/BOX (數量/盒)
7101-315	1.5 mm	300
7101-302	2 mm	240
7101-325	2.5 mm	150
7101-303	3 mm	100
7101-304	4 mm	60
7101-305	5 mm	70
7101-306	6 mm	30
7101-308	8 mm	20
7101-310	10 mm	10
7101-312	12 mm	6
7101-314	14 mm	6
7101-317	17 mm	6
7101-319	19 mm	5

**9PCS SHORT HEX L-WRENCH SET CR-V**

**9件 短 內六角扳手組 鉻釩鋼**

ITEM NO. (編號)	PCS/BOX (數量/盒)	PCS/CTN (數量/箱)	CUFT (材積)
7100-1A9	10	50	1.83'
SIZE(規格): H1.5 - H2 - H2.5 - H3 - H4 - H5 - H6 - H8 - H10 mm			

**9PCS LONG HEX L-WRENCH SET CR-V**

**9件 長 內六角扳手組 鉻釩鋼**

ITEM NO. (編號)	PCS/BOX (數量/盒)	PCS/CTN (數量/箱)	CUFT (材積)
7100-2A9	10	50	2.22'
SIZE(規格): H1.5 - H2 - H2.5 - H3 - H4 - H5 - H6 - H8 - H10 mm			

**9PCS EXTRA LONG HEX L-WRENCH SET CR-V**

**9件 特長 內六角扳手組 鉻釩鋼**

ITEM NO. (編號)	PCS/BOX (數量/盒)	PCS/CTN (數量/箱)	CUFT (材積)
7100-3A9	10	50	2.18'
SIZE(規格): H1.5 - H2 - H2.5 - H3 - H4 - H5 - H6 - H8 - H10 mm			





**9PCS BALL POINT SHORT HEX L-WRENCH SET CR-V。**  
**9件 短 球頭內六角扳手組 鉻釩鋼**

ITEM NO. (編號)	PCS/BOX (數量/盒)	PCS/CTN (數量/箱)	CUFT (材積)
7101-1A9	10	50	1.83'
SIZE(規格) : H1.5 - H2 - H2.5 - H3 - H4 - H5 - H6 - H8 - H10 mm			



**9PCS BALL POINT LONG HEX L-WRENCH SET CR-V。**  
**9件 長 球頭內六角扳手組 鉻釩鋼**

ITEM NO. (編號)	PCS/BOX (數量/盒)	PCS/CTN (數量/箱)	CUFT (材積)
7101-2A9	10	50	2.22'
SIZE(規格) : H1.5 - H2 - H2.5 - H3 - H4 - H5 - H6 - H8 - H10 mm			



**9PCS BALL POINT EXTRA LONG HEX L-WRENCH SET CR-V。**  
**9件 特長 球頭內六角扳手組 鉻釩鋼**

ITEM NO. (編號)	PCS/BOX (數量/盒)	PCS/CTN (數量/箱)	CUFT (材積)
7101-3A9	10	50	2.18'
SIZE(規格) : H1.5 - H2 - H2.5 - H3 - H4 - H5 - H6 - H8 - H10 mm			



**9PCS SHORT STAR L-WRENCH SET CR-V。**  
**9件 短 星型內六角扳手組 鉻釩鋼**

ITEM NO. (編號)	PCS/BOX (數量/盒)	PCS/CTN (數量/箱)	CUFT (材積)
7102-1A9	10	50	1.83'
SIZE(規格) : T10 - T15 - T20 - T25 - T27 - T30 - T40 - T45 - T50			



**9PCS LONG STAR L-WRENCH SET CR-V。**  
**9件 長 星型內六角扳手組 鉻釩鋼**

ITEM NO. (編號)	PCS/BOX (數量/盒)	PCS/CTN (數量/箱)	CUFT (材積)
7102-2A9	10	50	2.22'
SIZE(規格) : T10 - T15 - T20 - T25 - T27 - T30 - T40 - T45 - T50			



**9PCS EXTRA LONG STAR L-WRENCH SET CR-V。**  
**9件 特長 星型內六角扳手組 鉻釩鋼**

ITEM NO. (編號)	PCS/BOX (數量/盒)	PCS/CTN (數量/箱)	CUFT (材積)
7102-3A9	10	50	2.18'
SIZE(規格) : T10 - T15 - T20 - T25 - T27 - T30 - T40 - T45 - T50			



**55L & 80L 1/2"DR. PHILLIPS BIT SOCKET.**  
**1/2"DR. 十字 起子頭套筒**

ITEM NO. (編號)	SIZE (規格)	L/mm (長度/公釐)	PCS/BOX (數量/盒)	PCS/CTN (數量/箱)	CUFT (材積)
91200-03	PH3	55	10	200	0.76'
91200-04	PH4	55	10	200	0.76'
91212-03	PH3	80	10	200	0.76'
91212-04	PH4	80	10	200	0.76'



**55L & 80L 1/2"DR. HEXAGON BIT SOCKET.**  
**1/2"DR. 六角 起子頭套筒**

ITEM NO. (編號)	SIZE (規格)	L/mm (長度/公釐)	PCS/BOX (數量/盒)	PCS/CTN (數量/箱)	CUFT (材積)
91203-04	H4	55	10	200	0.76'
91203-05	H5	55	10	200	0.76'
91203-06	H6	55	10	200	0.76'
91203-07	H7	55	10	200	0.76'
91203-08	H8	55	10	200	0.76'
91203-10	H10	55	10	200	0.76'
91203-12	H12	55	10	200	0.76'
91203-14	H14	55	10	200	0.76'
91215-04	H4	80	10	200	0.76'
91215-05	H5	80	10	200	0.76'
91215-06	H6	80	10	200	0.76'
91215-07	H7	80	10	200	0.76'
91215-08	H8	80	10	200	0.76'
91215-10	H10	80	10	200	0.76'
91215-12	H12	80	10	200	0.76'
91215-14	H14	80	10	200	0.76'



**55L & 80L 1/2"DR. POZIDRIV BIT SOCKET.**  
**1/2"DR. 米字 起子頭套筒**

ITEM NO. (編號)	SIZE (規格)	L/mm (長度/公釐)	PCS/BOX (數量/盒)	PCS/CTN (數量/箱)	CUFT (材積)
91201-03	PZ3	55	10	200	0.76'
91201-04	PZ4	55	10	200	0.76'
91213-03	PZ3	80	10	200	0.76'
91213-04	PZ4	80	10	200	0.76'

**200L 55L & 80L 1/2"DR. TORX BIT SOCKET.**  
**1/2"DR. 星型 起子頭套筒**

ITEM NO. (編號)	SIZE (規格)	L/mm (長度/公釐)	PCS/BOX (數量/盒)	PCS/CTN (數量/箱)	CUFT (材積)
91206-08	T8	55	10	200	0.76'
91206-09	T9	55	10	200	0.76'
91206-10	T10	55	10	200	0.76'
91206-15	T15	55	10	200	0.76'
91206-20	T20	55	10	200	0.76'
91206-25	T25	55	10	200	0.76'
91206-27	T27	55	10	200	0.76'
91206-30	T30	55	10	200	0.76'
91206-40	T40	55	10	200	0.76'
91218-08	T8	80	10	200	0.76'
91218-09	T9	80	10	200	0.76'
91218-10	T10	80	10	200	0.76'
91218-15	T15	80	10	200	0.76'
91218-20	T20	80	10	200	0.76'
91218-25	T25	80	10	200	0.76'
91218-27	T27	80	10	200	0.76'
91218-30	T30	80	10	200	0.76'
91218-40	T40	80	10	200	0.76'
91236-50	T50	200	10	150	0.62'
91236-55	T55	200	10	120	0.51'
91236-60	T60	200	10	100	0.41'



**55L & 80L 1/2"DR. SLOTTED BIT SOCKET.**  
**1/2"DR. 一字 起子頭套筒**

ITEM NO. (編號)	SIZE (規格)	L/mm (長度/公釐)	PCS/BOX (數量/盒)	PCS/CTN (數量/箱)	CUFT (材積)
91202-08	SL8	55	10	200	0.76'
91202-10	SL10	55	10	200	0.76'
91202-12	SL12	55	10	200	0.76'
91214-08	SL8	80	10	200	0.76'
91214-10	SL10	80	10	200	0.76'
91214-12	SL12	80	10	200	0.76'





**8PCS RATCHETING COMBINATION WRENCH WALLET SET**

8件 棘輪複合扳手組

ITEM NO. (編號)	SET / BOX (數量/組/盒)	SET / CTN (數量/組/箱)	G.W. / KGS (毛重/公斤)
7400-A08	1	15	20.50
SIZE(規格): 10 - 11 - 12 - 13 - 14 - 17 - 19 - 22 mm			

**12PCS RATCHETING COMBINATION WRENCH WALLET SET**

12件 棘輪複合扳手組

ITEM NO. (編號)	SET / BOX (數量/組/盒)	SET / CTN (數量/組/箱)	G.W. / KGS (毛重/公斤)
7400-B12	1	15	22.50
SIZE(規格): 8 - 9 - 10 - 11 - 12 - 13 - 14 - 15 - 16 - 17 - 19 - 22 mm			

**RATCHETING COMBINATION WRENCH**

棘輪複合扳手

ITEM NO. (編號)	SIZE (規格)	ITEM NO. (編號)	SIZE (規格)
7400-0008	8mm	7400-0016	16mm
7400-0009	9mm	7400-0017	17mm
7400-0010	10mm	7400-0018	18mm
7400-0011	11mm	7400-0019	19mm
7400-0012	12mm	7400-0021	21mm
7400-0013	13mm	7400-0022	22mm
7400-0014	14mm	7400-0024	24mm
7400-0015	15mm		

**WRENCH**



**DOUBLE STAR RING WRENCH**

星型扳手

ITEM NO. (編號)	SIZE (規格)	ITEM NO. (編號)	SIZE (規格)
7322-0608	E6 X E8	7322-1418	E14 X E18
7322-0711	E7 X E11	7322-1622	E16 X E22
7322-1012	E10 X E12	7322-2024	E20 X E24



**RATCHETING FLEXIBLE COMBINATION WRENCH**

可彎式 棘輪複合扳手

ITEM NO. (編號)	SIZE (規格)	ITEM NO. (編號)	SIZE (規格)
7402-0008	8mm	7402-0014	14mm
7402-0009	9mm	7402-0015	15mm
7402-0010	10mm	7402-0016	16mm
7402-0011	11mm	7402-0017	17mm
7402-0012	12mm	7402-0018	18mm
7402-0013	13mm	7402-0019	19mm

**8PCS RATCHETING FLEXIBLE COMBINATION WRENCH WALLET SET**

8件 可彎式 棘輪複合扳手組

ITEM NO. (編號)	SET / BOX (數量/組/盒)	SET / CTN (數量/組/箱)	G.W. / KGS (毛重/公斤)
7402-A08	1	25	20.00
SIZE(規格): 10 - 11 - 12 - 13 - 14 - 17 - 19 - 22 mm			



**DOUBLE FLEXIBLE SOCKET WRENCH**

雙搖頭扳手

ITEM NO. (編號)	SIZE (規格)	PCS/BOX (數量/盒)	PCS/CTN (數量/箱)	CUFT (材積)
7330-0607	6X7	20	300	0.62'
7330-0809	8X9	20	240	0.51'
7330-1011	10X11	15	180	0.51'
7330-1213	12X13	20	120	0.6'
7330-1415	14X15	15	90	0.6'
7330-1617	16X17	9	54	0.6'
7330-1819	18X19	9	54	0.6'
7330-2022	20X22	5	30	0.6'
7330-2123	21X23	5	30	0.6'



**RATCHETING OFFSET RING WRENCH**

棘輪雙梅扳手

ITEM NO. (編號)	SIZE (規格)	ITEM NO. (編號)	SIZE (規格)
7410-0809	8 X 9	7410-1415	14 X 15
7410-0810	8 X 10	7410-1618	16 X 18
7410-1011	10 X 11	7410-1719	17 X 19
7410-1213	12 X 13		

**6PCS RATCHETING OFFSET RING WRENCH WALLET SET**

6件 棘輪雙梅扳手組

ITEM NO. (編號)	SET / BOX (數量/組/盒)	SET / CTN (數量/組/箱)	G.W. / KGS (毛重/公斤)
7410-A06	1	25	22.00
SIZE(規格): 8X9 10X11 12X13 14X15 16X18 17X19			



**6PCS FLARE NUT WRENCH WALLET SET**

**6件 油管扳手組**

ITEM NO. (編號)	SET / BOX (數量/組/盒)	SET / CTN (數量/組/箱)	G.W. / KGS (毛重/公斤)
7311-A06	1	25	24.00
SIZE(規格): 8X10 10X12 11X13 12X14 17X19 19X22			

**FLARE NUT WRENCH**

**油管扳手**

ITEM NO. (編號)	SIZE (規格)	ITEM NO. (編號)	SIZE (規格)
7311-0810	8X10	7311-1719	17X19
7311-0911	9X11	7311-1821	18X21
7311-1011	10X11	7311-1922	19X22
7311-1112	11X12	7311-2123	21X23
7311-1113	11X13	7311-2224	22X24
7311-1214	12X14	7311-2427	24X27
7311-1417	14X17	7311-2730	27X30
7311-1619	16X19	7311-3032	30X32



**8PCS COMBINATION WRENCH WALLET SET**

**8件 複合扳手組**

ITEM NO. (編號)	SET / BOX (數量/組/盒)	SET / CTN (數量/組/箱)	G.W. / KGS (毛重/公斤)
7300-A08	1	25	17.50
SIZE(規格): 10 - 11 - 12 - 13 - 14 - 17 - 19 - 22 mm			

**12PCS COMBINATION WRENCH WALLET SET**

**12件 複合扳手組**

ITEM NO. (編號)	SET / BOX (數量/組/盒)	SET / CTN (數量/組/箱)	G.W. / KGS (毛重/公斤)
7300-B12	1	20	22.00
SIZE(規格): 8 - 9 - 10 - 11 - 12 - 13 - 14 - 15 - 16 - 17 - 19 - 22 mm			

**14PCS COMBINATION WRENCH WALLET SET**

**14件 複合扳手組**

ITEM NO. (編號)	SET / BOX (數量/組/盒)	SET / CTN (數量/組/箱)	G.W. / KGS (毛重/公斤)
7300-B14	1	8	23.00
SIZE(規格): 10 - 11 - 12 - 13 - 14 - 16 - 17 - 19 - 21 - 22 - 24 - 27 - 30 - 32 mm			

**26PCS COMBINATION WRENCH WALLET SET**

**26件 複合扳手組**

ITEM NO. (編號)	SET / BOX (數量/組/盒)	SET / CTN (數量/組/箱)	G.W. / KGS (毛重/公斤)
7300-A26	1	4	22.50
SIZE(規格): 6-7-8-9-10-11-12-13-14-15-16-17-18-19-20-21-22-23-24-25-26-27-28-29-30-32 mm			

**COMBINATION WRENCH**

**複合扳手**

ITEM NO. (編號)	SIZE (規格)	PCS/BOX (數量/盒)	PCS/CTN (數量/箱)	CUFT (材積)
7300-0006	6mm	35	700	0.48'
7300-0007	7mm	35	700	0.48'
7300-0008	8mm	30	600	0.48'
7300-0009	9mm	25	500	0.48'
7300-0010	10mm	25	500	0.48'
7300-0011	11mm	15	300	0.48'
7300-0012	12mm	10	300	0.69'
7300-0013	13mm	20	300	0.62'
7300-0014	14mm	15	225	0.62'
7300-0015	15mm	15	225	0.62'
7300-0016	16mm	12	180	0.62'
7300-0017	17mm	30	180	0.65'
7300-0018	18mm	15	150	0.7'
7300-0019	19mm	15	150	0.7'
7300-0020	20mm	12	120	0.7'
7300-0021	21mm	12	120	0.7'
7300-0022	22mm	10	100	0.68'
7300-0023	23mm	10	80	0.58'
7300-0024	24mm	10	80	0.61'
7300-0025	25mm	10	60	0.48'
7300-0026	26mm	10	60	0.75'
7300-0027	27mm	10	60	0.75'
7300-0028	28mm	5	40	0.67'
7300-0029	29mm	5	40	0.67'
7300-0030	30mm	5	40	0.67'
7300-0032	32mm	5	40	0.67'



**DOUBLE OPEN WRENCH**

**雙開扳手**

ITEM NO. (編號)	SIZE (規格)	PCS/BOX (數量/盒)	PCS/CTN (數量/箱)	CUFT (材積)
7310-0607	6X7	40	800	0.48'
7310-0809	8X9	30	600	0.48'
7310-0810	8X10	30	600	0.48'
7310-1011	10X11	20	300	0.36'
7310-1012	10X12	20	300	0.36'
7310-1113	11X13	20	300	0.62'
7310-1213	12X13	20	300	0.62'
7310-1214	12X14	15	150	0.46'
7310-1415	14X15	15	150	0.46'
7310-1417	14X17	14	140	0.46'
7310-1617	16X17	14	140	0.46'
7310-1719	17X19	20	100	0.34'
7310-1819	18X19	20	100	0.34'
7310-1921	19X21	12	60	0.39'
7310-2022	20X22	12	60	0.39'
7310-2123	21X23	10	60	0.48'
7310-2427	24X27	10	60	0.48'
7310-2528	25X28	10	50	0.52'
7310-3032	30X32	10	50	0.52'

**8PCS DOUBLE OPEN WRENCH WALLET SET**

**8件 雙開扳手組**

ITEM NO. (編號)	SET / BOX (數量/組/盒)	SET / CTN (數量/組/箱)	G.W. / KGS (毛重/公斤)
7310-A08	1	25	24.00
SIZE(規格): 6X7 8X9 10X11 12X13 14X15 16X17 18X19 20X22			

**12PCS DOUBLE OPEN WRENCH WALLET SET**

**12件 雙開扳手組**

ITEM NO. (編號)	SET / BOX (數量/組/盒)	SET / CTN (數量/組/箱)	G.W. / KGS (毛重/公斤)
7310-A12	1	10	25.00
SIZE(規格): 6X7 8X9 10X11 12X13 14X15 16X17 18X19 20X22 21X23 24X27 25X28 30X32			



**8PCS 75 DEGREE OFFSET RING WRENCH WALLET SET**

**8件 75度 雙梅扳手組**

ITEM NO. (編號)	SET / BOX (數量/組/盒)	SET / CTN (數量/組/箱)	G.W. / KGS (毛重/公斤)
7320-A08	1	15	22.50
SIZE(規格): 6X7 8X9 10X11 12X13 14X15 16X17 18X19 21X23			

**12PCS 75 DEGREE OFFSET RING WRENCH WALLET SET**

**12件 75度 雙梅扳手組**

ITEM NO. (編號)	SET / BOX (數量/組/盒)	SET / CTN (數量/組/箱)	G.W. / KGS (毛重/公斤)
7320-A12	1	6	21.00
SIZE(規格): 6X7 8X9 10X11 12X13 14X15 16X17 18X19 20X22 21X23 24X27 25X28 30X32			

**75 DEGREE OFFSET RING WRENCH**

**75度 雙梅扳手**

ITEM NO. (編號)	SIZE (規格)	PCS/BOX (數量/盒)	PCS/CTN (數量/箱)	CUFT (材積)
7320-0607	6X7	10	350	0.54'
7320-0809	8X9	10	350	0.54'
7320-0810	8X10	10	350	0.54'
7320-1011	10X11	10	250	0.76'
7320-1012	10X12	10	250	0.76'
7320-1113	11X13	10	150	0.72'
7320-1213	12X13	10	150	0.72'
7320-1214	12X14	10	150	0.72'
7320-1415	14X15	10	150	0.72'
7320-1417	14X17	10	100	0.78'
7320-1617	16X17	10	100	0.78'
7320-1719	17X19	10	100	0.78'
7320-1819	18X19	10	100	0.78'
7320-1921	19X21	10	60	0.69'
7320-2022	20X22	10	60	0.69'
7320-2123	21X23	10	60	0.69'
7320-2224	22X24	10	40	0.65'
7320-2326	23X26	10	40	0.65'
7320-2426	24X26	10	40	0.65'
7320-2427	24X27	10	40	0.65'
7320-2528	25X28	10	40	0.65'
7320-3032	30X32	5	40	0.87'



**PT-IS408A-B**

1/2" DR. 8 PCS IMPACT SOCKET SET

1/2" DR. 8件氣動短套筒組

17 8 - IMPACT SOCKET 10-12-13-14-17-19-21-24MM

25 SETS/CTN  
G.W.: 23.30 KGS  
CUFT : 0.8'



**PT-IS410A-B**

1/2" DR. 10PCS IMPACT SOCKET SET

1/2" DR. 10件氣動短套筒組

17 9 - IMPACT SOCKET 10-12-13-14-17-19-21-22-24 MM  
1 - EXTENSION BAR 75MM

15 SETS/CTN  
G.W.: 19.60 KGS  
CUFT : 0.91'



**PT-IS414A-B**

1/2" DR. 14PCS IMPACT SOCKET SET

1/2" DR. 14件氣動短套筒組

17 13 - IMPACT SOCKET 10-11-12-13-14-15-16-17-19-21-22-23-24MM  
1 - EXTENSION BAR 75MM

10 SETS/CTN  
G.W.: 18.40 KGS  
CUFT : 0.9'



**PT-IS418A-B**

1/2" DR. 18PCS IMPACT SOCKET SET

1/2" DR. 18件氣動短套筒組

17 18 - IMPACT SOCKET  
10-11-12-13-14-15-16-17-18-19-20-21-22-23-24-27-30-32MM

8 SETS/CTN  
G.W.: 20.40 KGS  
CUFT : 0.75'



**PT-IBS408AH-B**

1/2"DR. 8PCS IMPACT HEX BIT SOCKET SET

1/2"DR. 8件氣動六角起子頭套筒組

17 8 - IMPACT HEX BIT SOCKET SET  
H5-H6-H7-H8-H10-H12-H14-H17

15 SETS/CTN  
G.W.: 18.32 KGS  
CUFT : 0.97'



**PT-IBS408AT-B**

1/2"DR. 8PCS IMPACT TORX BIT SOCKET SET

1/2"DR. 8件氣動星形起子頭套筒組

17 8 - IMPACT TORX BIT SOCKET SET  
T30-T40-T45-T50-T55-T60-T70-T80

15 SETS/CTN  
G.W.: 17.64 KGS  
CUFT : 0.97'



**PT-IBS408AM-B**

1/2"DR. 8PCS IMPACT SPLINE BIT SOCKET SET

1/2"DR. 8件氣動十二角起子頭套筒組

17 8 - IMPACT SPLINE BIT SOCKET SET  
M5-M6-M8-M10-M12-M14-M16-M18

15 SETS/CTN  
G.W.: 17.57 KGS  
CUFT : 0.97'



**PT-IS409B-M**  
1/2" DR. 9PCS IMPACT SOCKET SET  
1/2" DR. 9件氣動短套筒組

1/2 7 - IMPACT SOCKET 10-13-17-19-22-24-27MM  
1 - IMPACT UNIVERSAL JOINT  
1 - IMPACT EXTENSION BAR 125MM

12 SETS/CTN  
G.W.: 19.70 KGS  
CUFT : 0.57'



**PT-IS410A-M**  
1/2" DR. 10PCS IMPACT SOCKET SET  
1/2" DR. 10件氣動短套筒組

1/2 9 - IMPACT SOCKET 10-12-13-14-17-19-21-22-24MM  
1 - EXTENSION BAR 75MM

15 SETS/CTN  
G.W.: 22.45 KGS  
CUFT : 0.69'



**PT-IS410B-M**  
1/2" DR. 10PCS IMPACT SOCKET SET  
1/2" DR. 10件氣動短套筒組

1/2 10 - IMPACT SOCKET 10-12-13-14-15-16-17-18-19-22MM

15 SETS/CTN  
G.W.: 20.00 KGS  
CUFT : 0.69'



**PT-IS414A-M**  
1/2" DR. 14PCS IMPACT SOCKET SET  
1/2" DR. 14件氣動短套筒組

1/2 13 - IMPACT SOCKET 10-11-12-13-14-15-16-17-19-21-22-23-24MM  
1 - EXTENSION BAR 75MM

10 SETS/CTN  
G.W.: 18.82 KGS  
CUFT : 0.67'



**PT-IS418A-M**  
1/2" DR. 18PCS IMPACT SOCKET SET  
1/2" DR. 18件氣動短套筒組

1/2 18 - IMPACT SOCKET  
10-11-12-13-14-15-16-17-18-19-20-21-22-23-24-27-30-32MM

8 SETS/CTN  
G.W.: 23.12 KGS  
CUFT : 0.64'



**PT-IS608A-M**  
3/4" DR. 8PCS IMPACT SOCKET SET  
3/4" DR. 8件氣動短套筒組

3/4 8 - IMPACT SOCKET 22-24-27-30-32-36-38-41MM

4 SETS/CTN  
G.W.: 18.70 KGS  
CUFT : 0.41'



**PT-ISD409A-M**  
1/2" DR. 9PCS DEEP IMPACT SOCKET SET  
1/2" DR. 9件氣動長套筒組

1/2 9 - DEEP IMPACT SOCKET 10-12-13-14-17-19-21-22-24MM

8 SETS/CTN  
G.W.: 18.42 KGS  
CUFT : 0.53'



台灣製造  
**PERFECT TOOLS**®

MADE IN TAIWAN  
SINCE 2005



IMPACT  
SOCKET SET  
氣動套筒組



**PT-ISD410B-M**  
1/2" DR. 10PCS DEEP IMPACT SOCKET SET  
1/2" DR. 10件氣動長套筒組

172 9 - DEEP IMPACT SOCKET 13-14-15-16-17-18-19-22-24MM  
1 - IMPACT UNIVERSAL JOINT

10 SETS/CTN  
G.W.: 21.90 KGS  
CUFT : 0.85'



**PT-ISD411B-M**  
1/2" DR. 11PCS DEEP IMPACT SOCKET SET  
1/2" DR. 11件氣動長套筒組

172 11 - DEEP IMPACT SOCKET 10-12-13-14-15-16-17-18-19-22-24MM

6 SETS/CTN  
G.W.: 17.50 KGS  
CUFT : 0.51'



**PT-ISD413A-M**  
1/2" DR. 13PCS DEEP IMPACT SOCKET SET  
1/2" DR. 13件氣動長套筒組

172 13 - DEEP IMPACT SOCKET  
10-12-13-14-15-17-19-21-22-24-27-30-32MM

5 SETS/CTN  
G.W.: 22.60 KGS  
CUFT : 0.6'



**PT-ISD415B-M**  
1/2" DR. 15PCS DEEP IMPACT SOCKET SET  
1/2" DR. 15件氣動長套筒組

172 15 - DEEP IMPACT SOCKET  
10-12-13-14-15-16-17-18-19-21-22-24-27-30-32MM

4 SETS/CTN  
G.W.: 21.90 KGS  
CUFT : 0.79'



**PT-ISD608A-M**  
3/4" DR. 8PCS DEEP IMPACT SOCKET SET  
3/4" DR. 8件氣動長套筒組

174 8 - DEEP IMPACT SOCKET 22-24-27-30-32-36-38-41MM

3 SETS/CTN  
G.W.: 21.30 KGS  
CUFT : 0.42'



**PT-IBS408A-M78H**  
1/2" DR. 8PCS IMPACT HEX BIT SOCKET SET  
1/2" DR. 8件氣動六角起子頭套筒組

172 8 - IMPACT HEX BIT SOCKET 78L  
H5-H6-H7-H8-H10-H12-H14-H17

20 SETS/CTN  
G.W.: 29.98 KGS  
CUFT : 1.35'



**PT-IBS408A-M78T**  
1/2" DR. 8PCS IMPACT STAR BIT SOCKET SET  
1/2" DR. 8件氣動星型起子頭套筒組

172 8 - IMPACT STAR BIT SOCKET 78L  
T30-T40-T45-T50-T55-T60-T70-T80

20 SETS/CTN  
G.W.: 28.84 KGS  
CUFT : 1.35'



**PT-IBS408A-M78M**  
1/2" DR. 8PCS IMPACT SPLINE BIT SOCKET SET  
1/2" DR. 8件氣動十二角起子頭套筒組

172 8 - IMPACT SPLINE BIT SOCKET 78L  
M5- M6- M8- M10- M12- M14- M16- M18

20 SETS/CTN  
G.W.: 28.34 KGS  
CUFT : 1.35'



**3/8"** DR. IMPACT SOCKET PNEUMATIC CHROME VANADIUM  
氣動短套筒 鉻鈦鋼

ITEM NO. (編號)	SIZE (規格)	ITEM NO. (編號)	SIZE (規格)
8804-306	6mm	8804-313	13mm
8804-307	7mm	8804-314	14mm
8804-308	8mm	8804-315	15mm
8804-309	9mm	8804-316	16mm
8804-310	10mm	8804-317	17mm
8804-311	11mm	8804-318	18mm
8804-312	12mm	8804-319	19mm



**1/2"** DR. IMPACT SOCKET PNEUMATIC CHROME VANADIUM  
氣動短套筒 鉻鈦鋼

ITEM NO. (編號)	SIZE (規格)	PCS/BOX (數量/盒)	PCS/CTN (數量/箱)	ITEM NO. (編號)	SIZE (規格)	PCS/BOX (數量/盒)	PCS/CTN (數量/箱)
8804-408	8mm	16	320	8804-420	20mm	10	200
8804-409	9mm	16	320	8804-421	21mm	10	150
8804-410	10mm	16	320	8804-422	22mm	10	150
8804-411	11mm	16	320	8804-423	23mm	10	150
8804-412	12mm	16	320	8804-424	24mm	10	150
8804-413	13mm	16	320	8804-425	25mm	10	120
8804-414	14mm	16	320	8804-426	26mm	10	120
8804-415	15mm	10	200	8804-427	27mm	10	120
8804-416	16mm	10	200	8804-428	28mm	10	120
8804-417	17mm	10	200	8804-429	29mm	10	120
8804-418	18mm	10	200	8804-430	30mm	10	120
8804-419	19mm	10	200	8804-432	32mm	8	96



**3/4"** DR. IMPACT SOCKET CHROME MOLYBDENUM  
氣動短套筒 鉻鉬鋼

ITEM NO. (編號)	SIZE (規格)	PCS/BOX (數量/盒)	ITEM NO. (編號)	SIZE (規格)	PCS/BOX (數量/盒)
8800-617	17mm	10	8800-632	32mm	11
8800-618	18mm	10	8800-633	33mm	8
8800-619	19mm	10	8800-634	34mm	8
8800-620	20mm	10	8800-635	35mm	7
8800-621	21mm	10	8800-636	36mm	7
8800-622	22mm	10	8800-638	38mm	5
8800-623	23mm	10	8800-640	40mm	5
8800-624	24mm	10	8800-641	41mm	5
8800-625	25mm	12	8800-642	42mm	4
8800-626	26mm	12	8800-646	46mm	4
8800-627	27mm	12	8800-650	50mm	3
8800-628	28mm	12	8800-655	55mm	3
8800-629	29mm	12	8800-660	60mm	3
8800-630	30mm	12			



**3/8"** DR. DEEP IMPACT SOCKET PNEUMATIC CHROME VANADIUM  
氣動長套筒 鉻鈦鋼

ITEM NO. (編號)	SIZE (規格)	ITEM NO. (編號)	SIZE (規格)
8805-306	6mm	8805-313	13mm
8805-307	7mm	8805-314	14mm
8805-308	8mm	8805-315	15mm
8805-309	9mm	8805-316	16mm
8805-310	10mm	8805-317	17mm
8805-311	11mm	8805-318	18mm
8805-312	12mm	8805-319	19mm



**1/2"** DR. DEEP IMPACT SOCKET PNEUMATIC CHROME VANADIUM  
氣動長套筒 鉻鈦鋼

ITEM NO. (編號)	SIZE (規格)	PCS/BOX (數量/盒)	PCS/CTN (數量/箱)	ITEM NO. (編號)	SIZE (規格)	PCS/BOX (數量/盒)	PCS/CTN (數量/箱)
8805-408	8mm	15	120	8805-420	20mm	10	80
8805-409	9mm	15	120	8805-421	21mm	10	80
8805-410	10mm	15	120	8805-422	22mm	10	80
8805-411	11mm	15	120	8805-423	23mm	10	80
8805-412	12mm	15	120	8805-424	24mm	10	80
8805-413	13mm	15	120	8805-425	25mm	10	60
8805-414	14mm	10	100	8805-426	26mm	10	60
8805-415	15mm	10	100	8805-427	27mm	10	60
8805-416	16mm	10	100	8805-428	28mm	10	60
8805-417	17mm	10	80	8805-429	29mm	10	60
8805-418	18mm	10	80	8805-430	30mm	10	50
8805-419	19mm	10	80	8805-432	32mm	8	40



**3/4"** DR. IMPACT SOCKET CHROME MOLYBDENUM  
氣動長套筒 鉻鉬鋼

ITEM NO. (編號)	SIZE (規格)	PCS/BOX (數量/盒)	ITEM NO. (編號)	SIZE (規格)	PCS/BOX (數量/盒)
8801-617	17mm	12	8801-630	30mm	10
8801-618	18mm	12	8801-632	32mm	10
8801-619	19mm	12	8801-633	33mm	10
8801-620	20mm	10	8801-634	34mm	10
8801-621	21mm	10	8801-635	35mm	5
8801-622	22mm	10	8801-636	36mm	5
8801-623	23mm	10	8801-638	38mm	5
8801-624	24mm	10	8801-640	40mm	5
8801-625	25mm	10	8801-641	41mm	5
8801-626	26mm	10	8801-642	42mm	5
8801-627	27mm	10	8801-646	46mm	4
8801-628	28mm	10	8801-650	50mm	4
8801-629	29mm	10			





PERFECT TOOLS®

SINCE 2005



Tools best partner

IMPACT ACCESSORIES

氣動配件



### IMPACT UNIVERSAL JOINT

氣動萬向接頭 鉻鉬鋼

ITEM NO. (編號)	SIZE (規格)	PCS/BOX (數量/盒)	PCS/CTN (數量/箱)	CUFT (材積)
8816-3	3/8"DR.	20	200	0.7'
8816-4	1/2"DR.	15	150	0.7'
8816-6	3/4"DR.	10	100	0.7'
8816-1	1"DR.	5	50	0.7'



### 1/2"DR. IMPACT HEXAGON BIT SOCKET

1/2"DR. 氣動六角起子頭套筒 鉻鉬鋼

ITEM NO. (編號)	SIZE (規格)	L/mm (長度/公釐)	PCS/BOX (數量/盒)	PCS/CTN (數量/箱)	CUFT (材積)
91001-04	H4	78	25	250	0.41'
91001-05	H5	78	25	250	0.41'
91001-06	H6	78	25	250	0.41'
91001-07	H7	78	25	250	0.41'
91001-08	H8	78	22	220	0.41'
91001-09	H9	78	22	220	0.41'
91001-10	H10	78	20	200	0.41'
91001-11	H11	78	20	160	0.34'
91001-12	H12	78	20	160	0.34'
91001-14	H14	78	20	160	0.34'
91001-17	H17	78	18	108	0.26'
91001-19	H19	78	18	108	0.26'



### IMPACT SOCKET ADAPTOR

氣動互換接頭 鉻鉬鋼

ITEM NO. (編號)	SIZE (規格)	PCS/BOX (數量/盒)	PCS/CTN (數量/箱)	CUFT (材積)
8818-03	3/8" F X 1/2" M	20	400	0.48'
8818-04	1/2" F X 3/8" M	15	300	0.48'
8818-05	1/2" F X 3/4" M	10	200	0.48'
8818-06	3/4" F X 1/2" M	4	80	0.48'
8818-07	3/4" F X 1" M	2	40	0.48'



### 1/2"DR. IMPACT STAR BIT SOCKET

1/2"DR. 氣動星型起子頭套筒 鉻鉬鋼

ITEM NO. (編號)	SIZE (規格)	L/mm (長度/公釐)	PCS/BOX (數量/盒)	PCS/CTN (數量/箱)	CUFT (材積)
91003-25	T25	78	25	250	0.41'
91003-27	T27	78	25	250	0.41'
91003-30	T30	78	25	250	0.41'
91003-35	T35	78	25	250	0.41'
91003-40	T40	78	20	200	0.41'
91003-45	T45	78	20	200	0.41'
91003-50	T50	78	20	200	0.41'
91003-55	T55	78	20	200	0.34'
91003-60	T60	78	20	160	0.34'
91003-70	T70	78	20	160	0.34'
91003-90	T90	78	18	108	0.26'
91011-52	T52	125	12	144	0.51'



### IMPACT EXTENSION BAR

氣動接桿 3/8" & 1/2"DR. 鉻鉬鋼

ITEM NO. (編號)	SIZE (規格)	L/mm (長度/公釐)	PCS/BOX (數量/盒)	PCS/CTN (數量/箱)	CUFT (材積)
8814-303	3/8"DR.	75	20	300	0.36'
8814-306	3/8"DR.	150	10	150	0.36'
8814-403	1/2"DR.	75	15	150	0.41'
8814-405	1/2"DR.	125	10	100	0.4'
8814-410	1/2"DR.	250	5	50	0.4'

### IMPACT EXTENSION BAR

氣動接桿 3/4"DR. 鉻鉬鋼

ITEM NO. (編號)	SIZE (規格)	L/mm (長度/公釐)	PCS/BOX (數量/盒)	PCS/CTN (數量/箱)	CUFT (材積)
8812-604	3/4"DR.	100	4	24	0.6'
8812-607	3/4"DR.	175	2	12	0.61'
8812-610	3/4"DR.	250	2	12	0.61'
8812-613	3/4"DR.	325	2	8	0.6'
8812-107	1"DR.	175	2	12	0.61'
8812-110	1"DR.	250	2	12	0.61'
8812-113	1"DR.	325	2	8	0.6'



### 1/2"DR. IMPACT STAR BIT SOCKET

1/2"DR. 氣動星型起子頭套筒 鉻鉬鋼 (中孔)

ITEM NO. (編號)	SIZE (規格)	L/mm (長度/公釐)	PCS/BOX (數量/盒)	PCS/CTN (數量/箱)	CUFT (材積)
91004-80	TT80	78	20	120	0.26'
91004-100	TT100	78	18	108	0.26'

### 1/2"DR. IMPACT SPLINE BIT SOCKET

1/2"DR. 氣動十二角起子頭套筒 鉻鉬鋼

ITEM NO. (編號)	SIZE (規格)	L/mm (長度/公釐)	PCS/BOX (數量/盒)	PCS/CTN (數量/箱)	CUFT (材積)
91005-05	M5	78	25	250	0.41'
91005-06	M6	78	25	250	0.41'
91005-08	M8	78	25	250	0.41'
91005-10	M10	78	20	200	0.41'
91005-12	M12	78	20	200	0.41'
91005-14	M14	78	20	160	0.34'
91005-16	M16	78	20	160	0.34'
91005-18	M18	78	20	160	0.34'

### 1/2"DR. IMPACT SPLINE BIT SOCKET

1/2"DR. 氣動十二角起子頭套筒 鉻鉬鋼 (中孔)

ITEM NO. (編號)	SIZE (規格)	L/mm (長度/公釐)	PCS/BOX (數量/盒)	PCS/CTN (數量/箱)	CUFT (材積)
91006-17	TM17	78	20	160	0.34'



**PERFECT TOOLS**®

SINCE 2005



Tools best partner

**TORQUE WRENCH**  
扭力扳手



**1/4" DR. TORQUE WRENCH**

**1/4" DR. 扭力扳手**

ITEM NO. (編號)	SET / BOX (數量/盒)	SET / CTN (數量/箱)	G.W. / KGS (毛重/公斤)	CUFT (材積)
7280-2A	1	20	14.00	0.9'
CONTENTS(產品規格): 2-24NM(牛頓米) & 0.2-2.4KGM(公斤米)				
BLOW MOLD CASE(吹氣盒)				



**3/8" DR. TORQUE WRENCH**

**3/8" DR. 扭力扳手**

ITEM NO. (編號)	SET / BOX (數量/盒)	SET / CTN (數量/箱)	G.W. / KGS (毛重/公斤)	CUFT (材積)
7280-3B	1	15	17.50	1.03'
CONTENTS(產品規格): 7-105NM(牛頓米) & 0.7-10.7KGM(公斤米)				
BLOW MOLD CASE(吹氣盒)				



**1/2" DR. TORQUE WRENCH**

**1/2" DR. 扭力扳手**

ITEM NO. (編號)	SET / BOX (數量/盒)	SET / CTN (數量/箱)	G.W. / KGS (毛重/公斤)	CUFT (材積)
7280-4A	1	12	20.00	1.3'
CONTENTS(產品規格): 28-210NM(牛頓米) & 2.9-21.4KGM(公斤米)				
BLOW MOLD CASE(吹氣盒)				

**1/2" DR. TORQUE WRENCH**

**1/2" DR. 扭力扳手**

ITEM NO. (編號)	SET / BOX (數量/盒)	SET / CTN (數量/箱)	G.W. / KGS (毛重/公斤)	CUFT (材積)
7280-4C	1	8	22.00	0.88'
CONTENTS(產品規格): 70-350NM(牛頓米) & 7.13-35.69KGM(公斤米)				
BLOW MOLD CASE(吹氣盒)				



**3/4" DR. TORQUE WRENCH**

**3/4" DR. 扭力扳手**

ITEM NO. (編號)	SET / BOX (數量/盒)	SET / CTN (數量/箱)	G.W. / KGS (毛重/公斤)	CUFT (材積)
7280-6B	1	6	21.00	1.1'
CONTENTS(產品規格): 70-420NM(牛頓米) & 7.14-42.8KGM(公斤米)				
BLOW MOLD CASE(吹氣盒)				

**3/4" DR. TORQUE WRENCH**

**3/4" DR. 扭力扳手**

ITEM NO. (編號)	SET / BOX (數量/盒)	SET / CTN (數量/箱)	G.W. / KGS (毛重/公斤)	CUFT (材積)
7280-6C	1	2	15.00	1.2'
CONTENTS(產品規格): 140-700NM(牛頓米) & 14.28-71.38KGM(公斤米)				
BLOW MOLD CASE(吹氣盒)				